

**SUNSHINE<sup>®</sup>**

Industrial Sewing Machines.

# **MODEL 3400 SERIES**

## **INSTRUCTION MANUAL**

**MOD. 3404P  
3404PMD  
3406PTA  
3412P  
3412PS**

Picture No. 1.

Finish.

1. Stitching form	78702, 78704, 78706, 78708, 78710 and 78712
2. Needles	2 needles to 12 needles
3. Threads	4 threads to 24 threads
4. Needle number	ORGAN UO 113 11-18
5. Needle gauge	5mm – 70mm
6. Needle bar stroke	34.5 mm
7. Feed mechanism	Plain feed system
8. Standard stitch length	24/1" – 6/1"
9. Lubrication	Full automatic oiling system
10. Rotating speed of this kind machine on 60Hz	About 4,500 RPM.

Fig 1

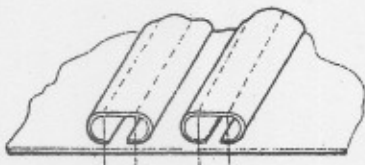

78704 PL

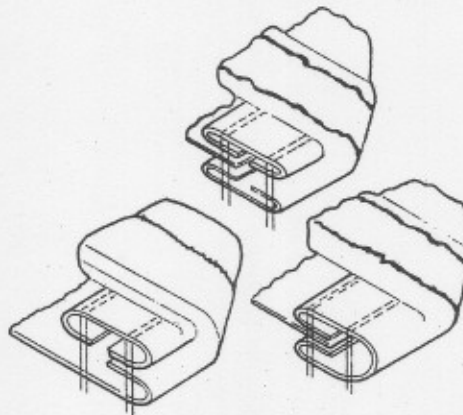

78704 WB

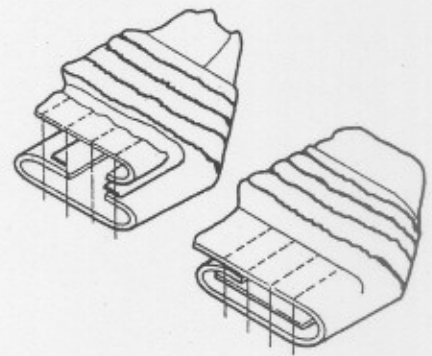

78704 PMD



78706 PL

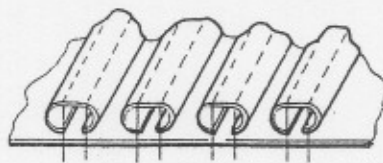

78708 PL



78712 PL

Picture No. 2.

Setting the machines.

The setting of this machines is used a half sink type table.

As for the setting of table and stand, please refer to another diagram for setting.

Picture No. 3.

The selection of the motor pulley.

The relation and comparison between the rotating (RPM) of machines and motor pulley size is as following. Please select the motor pulley according to RPM.

R. P. M.	Diameter of motor pulley	
	50Hz	60Hz
4,500	105	90
4,000	95	80
3,500	85	70

Table 1.

Picture No. 4.

The changing of the needles.

Please set the needle to be just side against the front as indicated in Fig. 2, because the mechanism of this kind machines have a side moving system.

Since the needle and looper has the close relation, please be careful in changing the needles. The uncorrect setting needle causes not only the mis-stitching and cutting the threads but also the looper breakage.

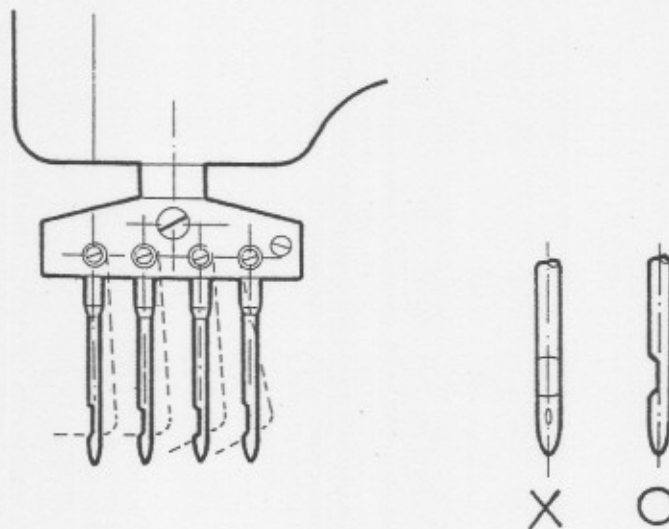

Fig 2

Picture No. 5.

The oil supplying and putting out.

The most suitable oil for our all products is the SF oil.

For putting out the oil, please change oil at the time about 30 days passes after starting to use. Please do the oil supplying as follows.

1. Please supply the oil after loosening the siphone case in Fig. 3.
2. As for the capacity of oil, the oil should be maintained between the red lines on the gauge.
3. Please check whether the oil jets the siphone case and the lubrication is done completely.

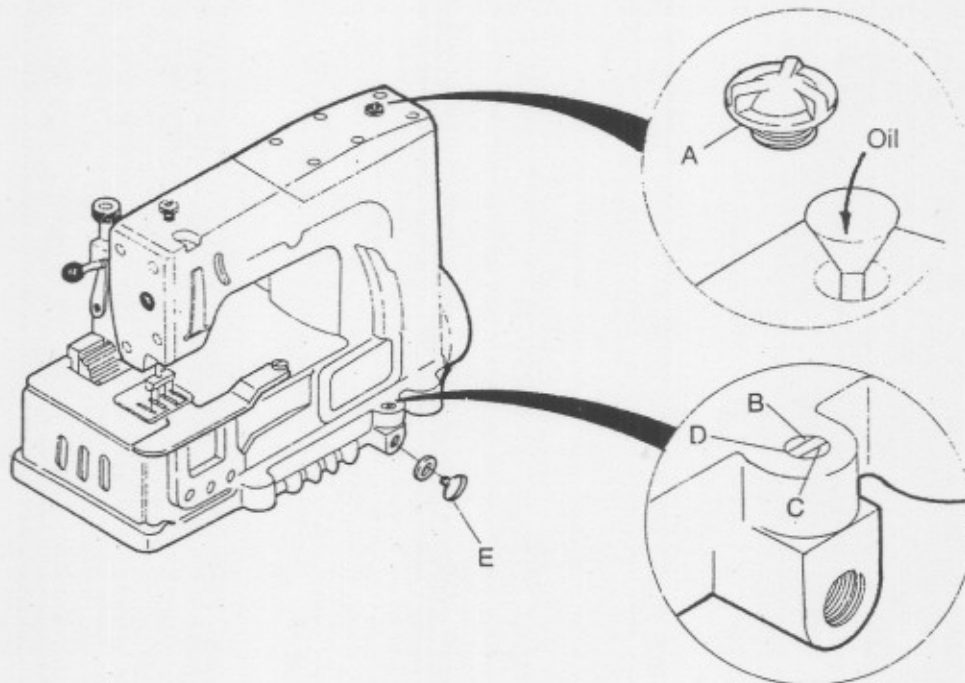

Fig 3

Putting out the oil.

Please put out the oil after loosening the screw E in Fig. 3. at the bottom of the oil pan.

**NOTICE**

1. Please never fail to check the oil gauge and maintain the enough oil before starting the machines.
2. Please use the genuine oil and high quality oil for sewing machines.
3. If the oil does not jet to siphone case smoothly and completely in spite of the oil filling much in oil tank, please check the oil pump mesh.

Picture No. 6.

Threading and the adjustment of tension.

Please adjust correctly as following Fig. 4.

1. A, B, C, D is the thread of needle.
2. E, F, G, H is the thread on looper.
3. In threading to the needle, please thread right to left.
4. As to the adjustment of tension, if turning the tension disc to left, the tension becomes weak, and doing oppositely, it becomes strong.
5. In threading to looper, after pulling the looper throw-out actuating shaft A in Fig. 5. toward the arrow and then throwing down the looper rocker to the front, and please thread into the needle.

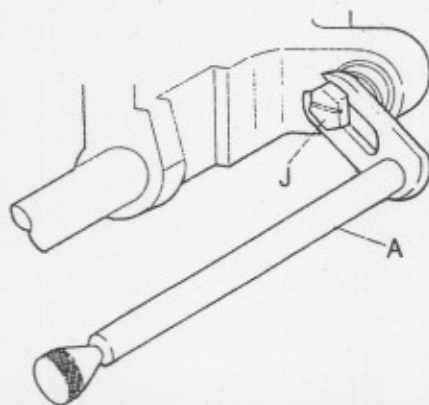
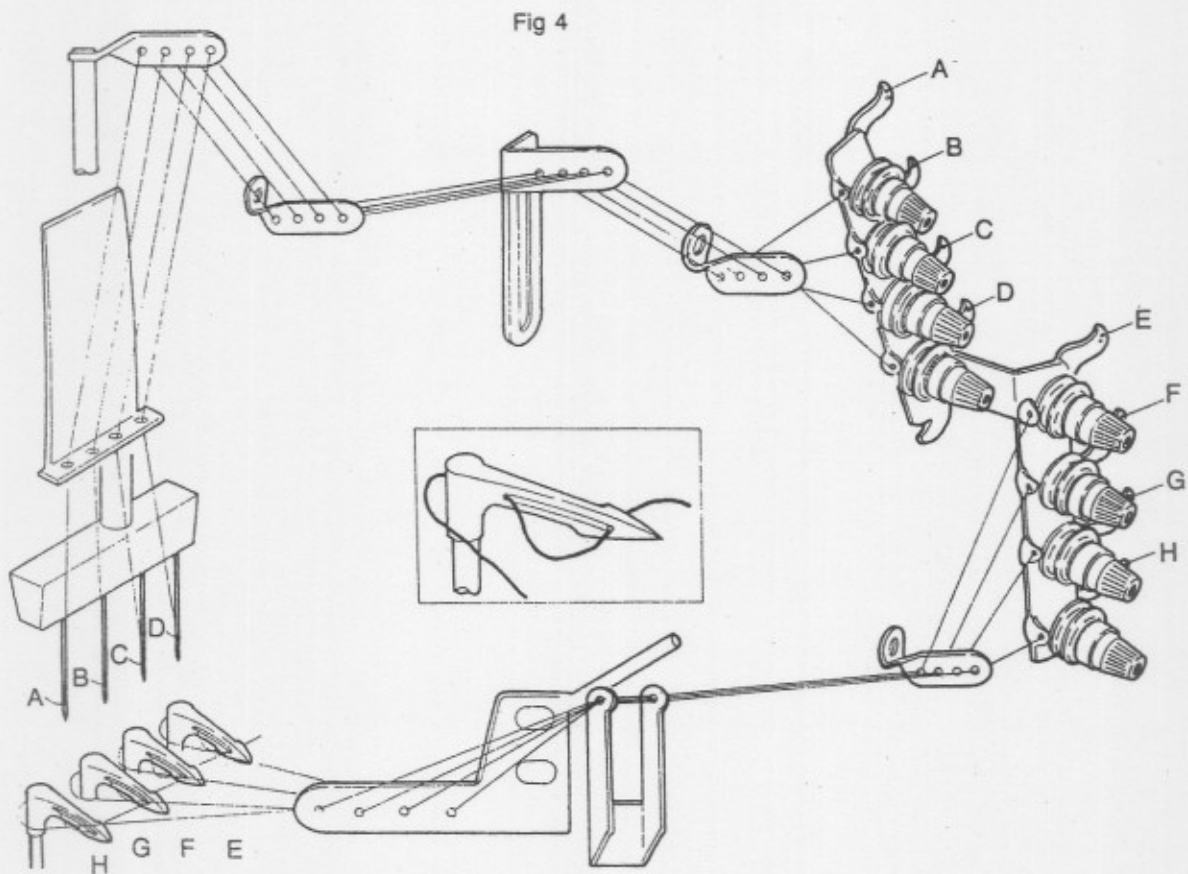

Fig 5

Picture No. 7.

The synchronization of needle bar and looper.

The going and returning looper synchronization against the needle bar stroke is as follows.

The going synchronization of looper is at the time when the needle bar rises 7mm to upward from its lower end (this time, the top end of looper must be far 2mm from the center of needle hole. Refer to Fig. 6.)

The returning synchronization of looper is at the time when the needle bar falls 28mm to downwards from its upper end (this time, the top end of looper must be necessary 3.5mm distance from the center of needle hole. Refer to Fig. 7.)

As for the adjustment of synchronization, please do according to following.

1. Firstly, remove the upper base cover and top oil cover.
2. Please loosen the looper front and rear eccentric screw E in Fig. 8.
3. When the looper front and rear eccentric M in Fig. 8. is moved to counterclockwise, the synchronization of looper becomes faster, and is done to clockwise, the synchronization of looper becomes slower.
4. Turning the pulley, the correct synchronization of looper is selected, please tighten the screw E in Fig. 8.

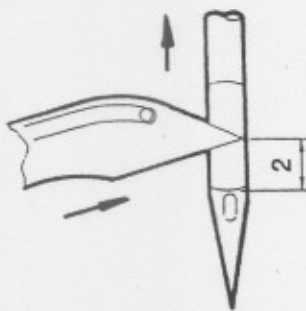

Fig 6

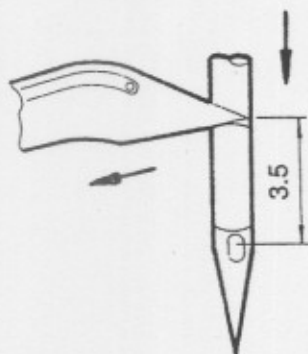

Fig 7

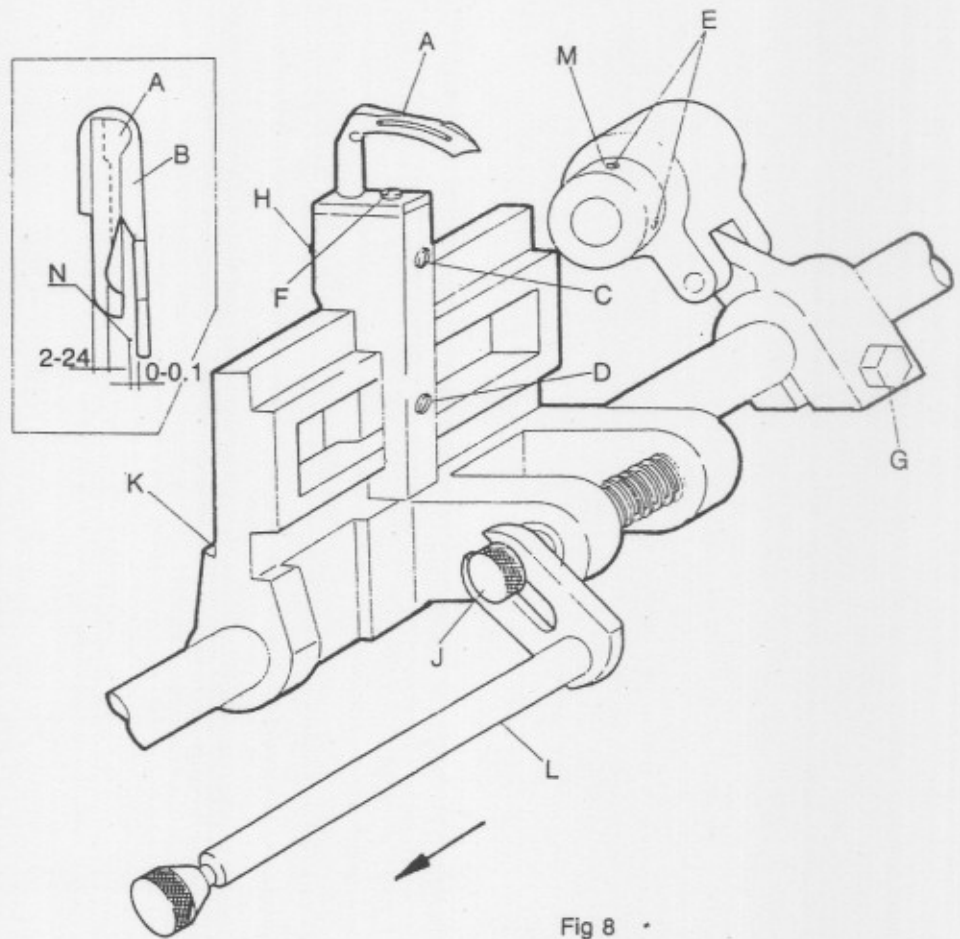

Fig 8

Picture No. 8

The adjustment of needle guard.

The adjustment of needle guard against the needle bar stroke. It is the suitable distance 0-0.1mm as indicated in Fig. 8. As for the adjustment, please do as follows.

1. Loosen the needle guard screw F in Fig. 8.
2. If the distance of needle guard becomes 0-0.1mm, please tighten the screw F in Fig. 8.

Picture No. 9.

The adjustment of needle bar height.

Needle bar height of this machine is 14mm from the surface of needle plate.

For adjusting, please do as following turns.

1. Rotating the pulley and raise the needle bar to upper end and then loosen the needle bar screw A in Fig. 9.
2. When the needle bar is put down, tighten the needle bar screw A in Fig. 9. moving the needle holder so that the needle can enter the center of needle hole.

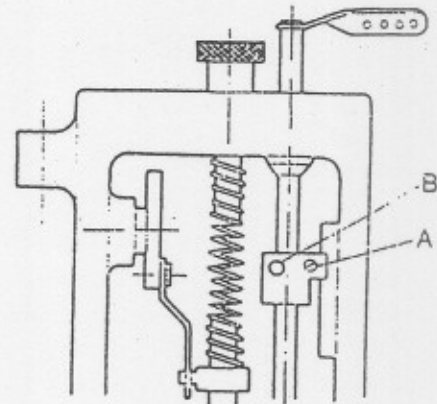

Fig 9

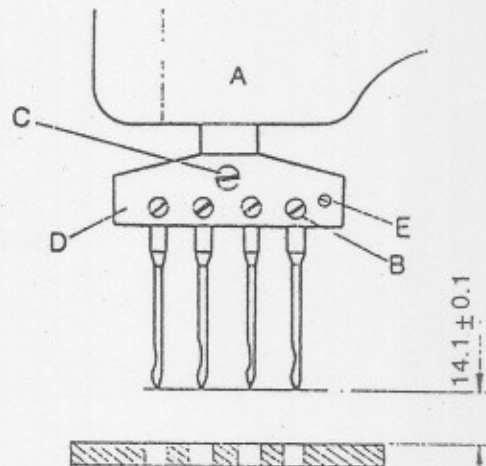

Fig 10

Picture No. 10.

The setting position of needle and looper.

The clearance of needle and looper, it is the most suitable to take 0.1mm.

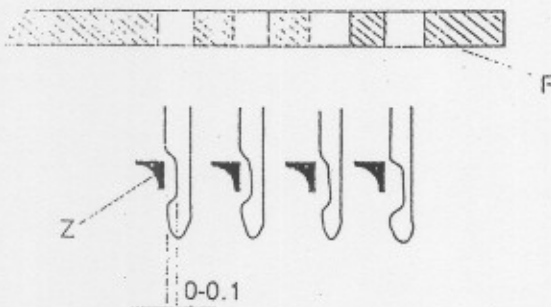

Fig 11

For the adjusting, please refer to the belows.

1. Loosen the looper screw C in Fig. 8.
2. Rotating the pulley, when the clearance of needle and looper becomes 0.1mm, and then please tighten the looper screw C in Fig. 8.

NOTICE.

Please set the looper vertically and horizontally on looper rocker because the looper of this machines works the same trace.

Picture No. 11.

The distance of the looper and needle.

When the needle bar at the lower end position, the distance of looper and needle is 2.6mm as indicated in Fig. 12.

For the adjustment, please do as following turns.

1. Loosen the looper rocker stopper screw A in Fig. 13.
2. In moving the looper rocker stopper in Fig. 13. to counterclockwise, the distance becomes shorter, and moving to clockwise, the distance becomes longer. When the distance is decided correctly, please tighten the screw A in Fig. 13.

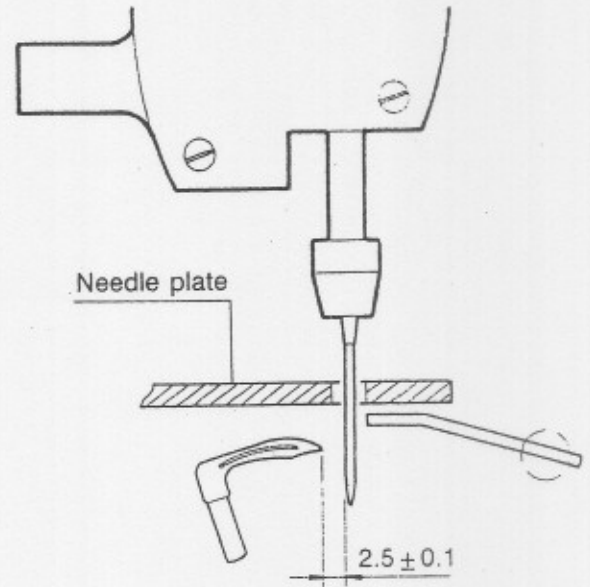

Fig 12

Picture No. 12.

The height of feed dog.

At the time when the feed dog becomes extreme upper end position, the height of feed dog from the surface of needle plate is 0.8mm - 1.5mm as indicated in Fig. 14.

For the adjustment, please do as followings.

1. Firstly, loosen the feed dog screw C in Fig. 14.
2. After moving the feed dog up to down, the correct height is setted, please tighten the screw C in Fig. 14.

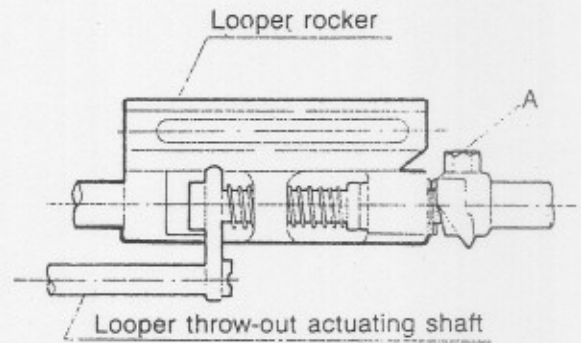

Fig 13

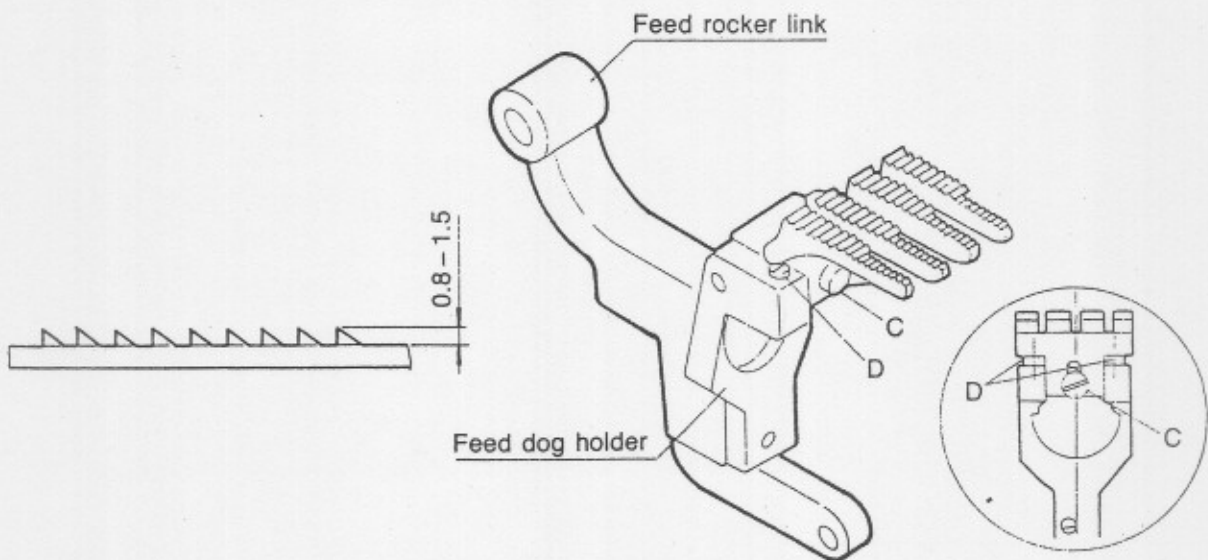

Fig 14



Picture No. 13.

The adjustment of feeding of dog.

Referring the adjustment, please do according to the following.

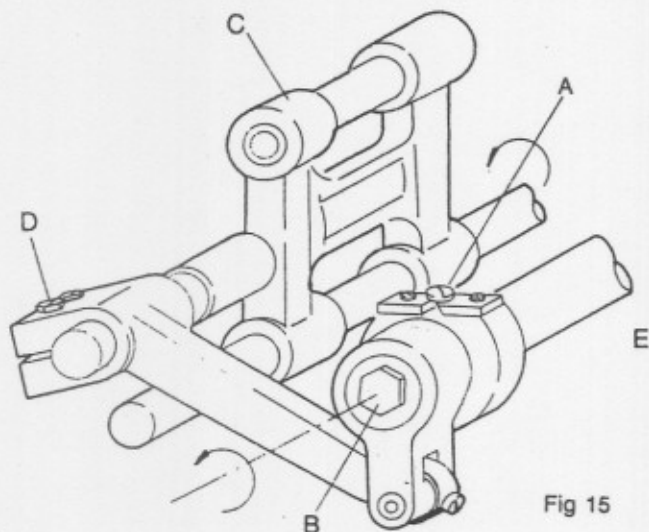

Fig 15

1. If turning the feed adjusting nut 8 in Fig 15. to the counterclockwise, this nut is going to be loosened.
2. Inturning the feed adjusting screw A in Fig. 15. to right, feeding becomes smaller and doing to left, the feeding becomes bigger.
3. The adjustment is decided correctly, please tighten the feed adjusting nut B in Fig. 15.

Picture No. 14.

The adjustment of spreader.

A. The correct distance between needle and spreader is 0.5mm - 0.8mm as indicated in Fig. 16.

As to the adjustment, please refer to the following.

1. Firstly, loosen the spreader screw A in Fig. 16.
2. Keeping the needle bar at the extreme lower end, and then check the spreader whether being setted horizontally, at the same time, please adjust the distance of spreader.
3. After the correct distance is decided, please tighten the screw A in Fig. 16.

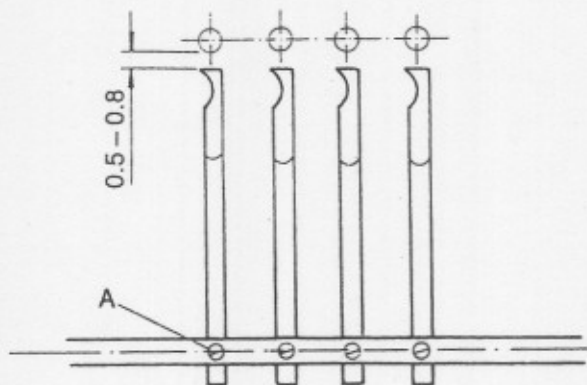

Fig 16

Picture No. 14.

The adjustment of spreader.

B. The position between looper and spreader, the correct position is that the right end of spreader locates toward right taking a distance 0.5mm from the center of looper, at the time when the spreader being at the extreme left position. The distance between spreader and looper is 0.1mm. Please refer to Fig. 17.

As to the adjustment of the above mentioned 2 items, please do as follows.

1. Loosen the retainer bar holder screw A in Fig 17. and after tighten it provisionally.
2. Rotating the pulley and keeping the spreader at the extreme left position, please adjust the position and distance between the looper and spreader. After the position and distance is decided, tighten the screw A in Fig. 17.

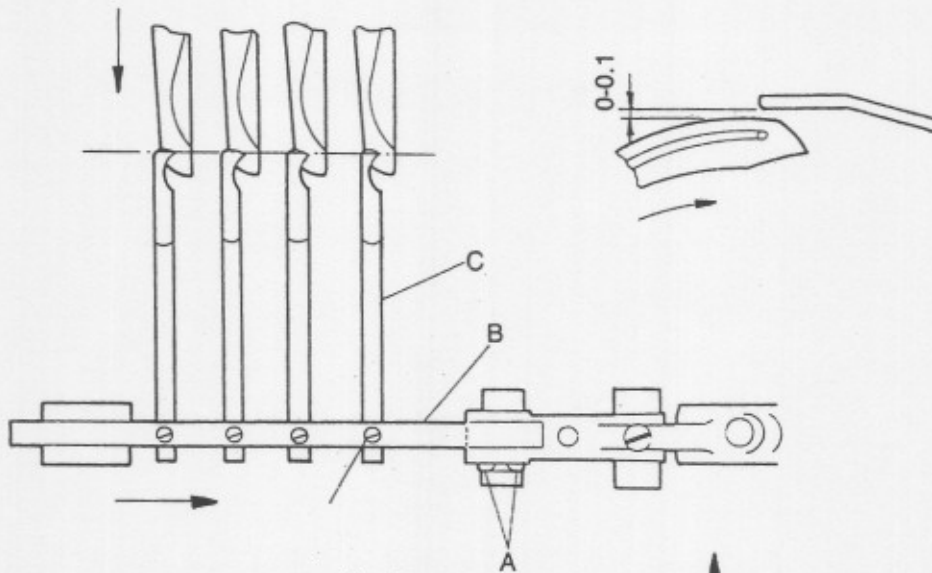

Fig 17

Picture No. 15.

The adjustment of needle thread take-up.

The adjustment of needle thread take-up is to be done by the kind of using threads, and is adjusted by moving the screw E in Fig 18. up to down.

In the case of threads whose tension is expansible, the loop resulting in the needle hole becomes larger, if putting the needle thread take-up to upwards.

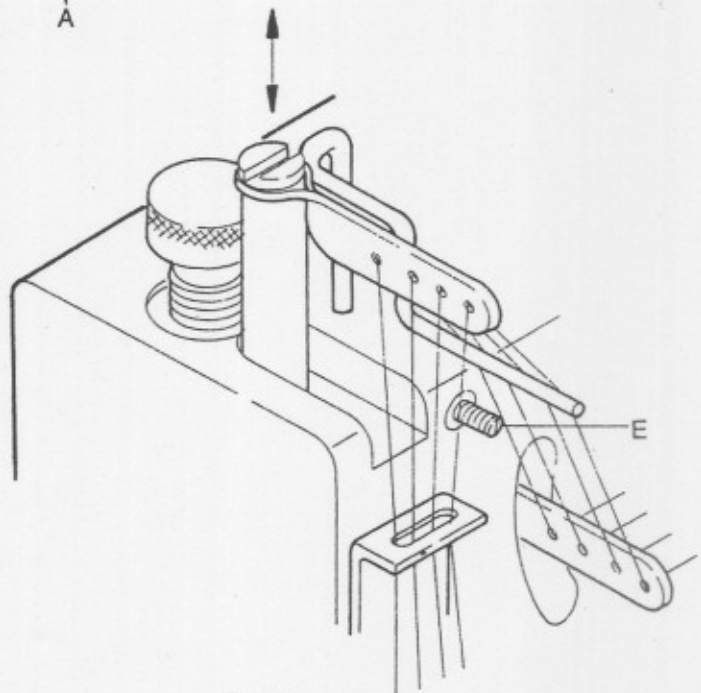

Fig 18

Picture No. 16.

The adjustment of looper retainer.

The looper retainer is to be adjusted at the time the needle bar is fell down 20mm from the upper end position (this time, the needle is in the center at the back of looper) so that the retainer bar can move to upwards.

For adjusting, please do as following.

1. Loosen the retainer eccentric screw H in Fig. 19. and then tighten this screw provisionally.
2. Rotating the pulley, adjust the looper retainer to be correct. This time, in turning the retainer eccentric I in Fig 19. to counterclockwise, the looper retainer becomes faster, and doing to clockwise, the looper retainer becomes slower.
3. For the subtle adjustment, loosen the screw G in Fig 19. and then adjust by moving the retainer thread eyelet up to down.

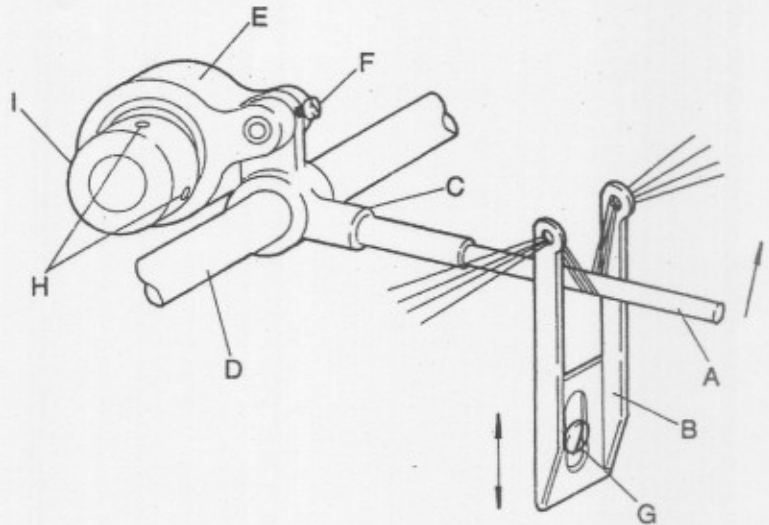

Fig 19

Picture No. 17.

The synchronization of puller.

A. The synchronizing of puller is that the needle bar is at the rising 24mm from its lower end position. As to the adjustment, please refer to the following turns.

1. Loosen the upper shaft eccentric screw B in Fig 20. and then tighten this screw provisionally.
2. Turning the pulley, and the correct synchronizing of puller is selected, please tighten screw A in Fig 20. This time, if turning the upper shaft eccentric to the front, the synchronizing becomes faster, and doing oppositely, it becomes slower.

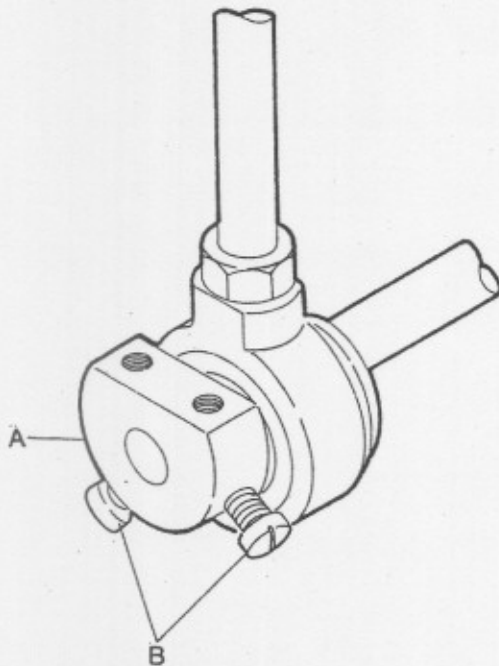

Fig 20

Picture No. 17.

The synchronization of puller.

B. As to the puller moving, please adjust it as following turns.

1. Firstly, remove the puller driving connecting cover.
2. Loosen the puller driving connecting ball joining nut B in Fig. 21.
3. When the puller driving connecting ball joint C in Fig 21. is turned to counterclockwise, the moving becomes lesser, and is done contrarily, it becomes more.
4. According to the situation, please do adjust accordingly.

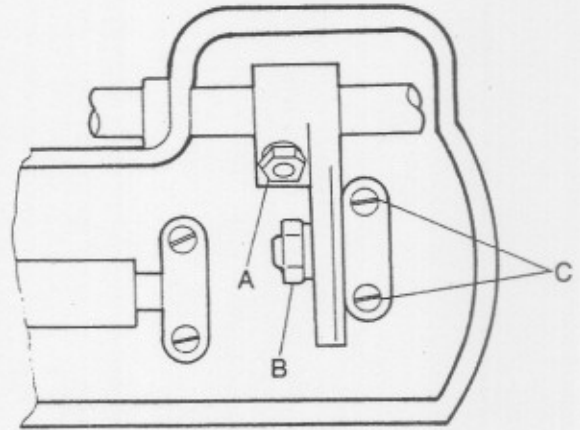

Fig 21

C. As to the puller feeding adjustment, please do adjusting as follows, according to the stitch length.

1. Loosen the upper shaft lever nut C in Fig 22.
2. When the upper shaft lever B in Fig 22. is moved to upwards, the feeding becomes lesser, and is done to downwards, the feeding becomes more.
3. Please adjust the feeding according to all of the stitch lengths.

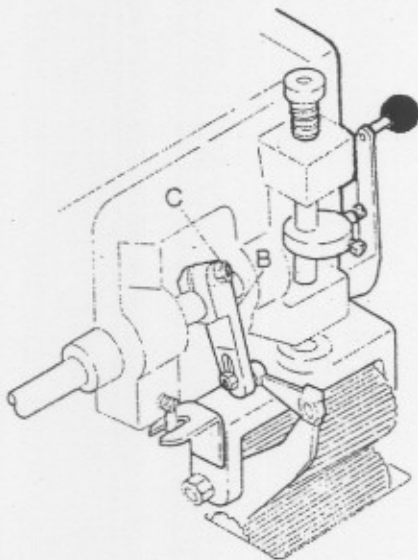

Fig 22