

GLOBAL

BT 2900 / BS 2903

**Electronically bartack machine
Electronic Lockstitch Button Sewer**

INSTRUCTION MANUAL

	Chapter-Page
Contents	
BT 2900 SERIES	
1	Safety1-1
1.01	Directives1-1
1.02	General notes on safety.....1-1
1.03	Safety symbols1-2
1.04	Important points for the user.....1-2
1.05	Operating and specialist personnel1-3
1.05.01	Operating personnel.....1-3
1.05.02	Specialist personnel1-3
1.06	Danger1-4
2	Proper use2-1
3	Specifications3-1
4	Disposal of machine.....4-1
5	Transport, packing and storage5-1
5.01	Transport to the customer.....5-1
5.02	Transport within the customer' s premises.....5-1
5.03	Disposal of the packaging.....5-1
5.04	Storage.....5-1
6	Explanation of the symbols6-1
7	Control elements7-1
7.01	Main switch.....7-1
7.02	Pedal.....7-1
7.03	Balance wheel.....7-2
7.04	Description of operation panel7-3
8	Installation and commissioning8-1
8.01	Installation8-1
8.01.01	Adjusting the table height8-1
8.01.02	Removing the transit support8-2
8.01.03	Fitting the reel stand8-2
8.01.04	Mounting the table top(for deliveries without stand)8-3
8.01.05	Table top drill hole plans8-4
8.01.06	Connecting the plug-in connections and earth cable8-5
8.01.06-1	Connector diagram of main board for stepping motor8-5
8.01.06-2	Connector diagram of driving board for stepping motor.....8-6
8.02	Commissioning the machine.....8-6
8.03	Switching the machine on/off8-6

Contents

	Contents	Chapter-Page
9	Setting up	9-1
9.01	Inserting the needle	9-1
9.02	Threading the needle thread/adjusting the needle thread tension...	9-2
9.03	Winding the bobbin thread.....	9-3
9.04	Removing/replacing the bobbin case	9-4
9.05	Threading the bobbin thread/adjusting the bobbin thread tension...	9-4
9.06	Performed setting of pattern sewing.....	9-5
10	Sewing	10-1
10.01	Operating cycle.....	10-1
11	Input.....	11-1
11.01	Enter M1&M2 parameter zone and setting of pattern.....	11-1
11.02	P key(Hot key) organization	11-2
11.03	Group setting.....	11-3
11.04	Self-test & restore default.....	11-4
11.05	Restore default.....	11-4
11.06	Self-diagnosis I	11-5
11.07	Control box automatic detection II	11-6
11.08	Constructs your own pattern and the operation mode.....	11-7
11.09	How to edit your own pattern(U01~U10)	11-8
11.10	Identify input coordinate file form.....	11-9
11.11	HSR2000.GSV file form.....	11-9
11.12	Table of the standard patterns I	11-10
11.12	Table of the standard patterns II	11-11
11.13	Parameters list	11-12
11.14	7-Segment display characters compare table.....	11-17
11.15	Error code and corrective measure.....	11-18
12	Care and maintenance	12-1
12.01	Maintenance intervals.....	12-1
12.02	Cleaning the machine	12-1
12.03	Cleaning the hook compartment.....	12-2
12.04	Oiling the needle head parts.....	12-2
12.05	Oiling the hook.....	12-3
12.06	Oiling the bearing points in the arm.....	12-4
12.07	Oiling disposal.....	12-4
13	Operation for particular patterns.....	13-1

	Contents	Chapter	Page
14	Adjustment		14-1
14.01	Notes on adjustment.....		14-1
14.02	Tools, gauges and other accessories.....		14-1
14.03	Abbreviations.....		14-1
14.04	Explanation of the symbols		14-1
14.05	Basic position of the machine.....		14-2
14.06	Work clamp zero point.....		14-3
14.07	Aligning the work clamp.....		14-5
14.08	Hook driver.....		14-7
14.09	Needle height.....		14-8
14.10	Hook-to-needle clearance		14-9
14.11	Needle rise and needle guard.....		14-10
14.12	Aligning the hook race cover.....		14-11
14.13	Work clamp height		14-12
14.14	Position of the thread wiper.....		14-13
14.15	Position of the control cam		14-14
14.16	Position of the control roller.....		14-15
14.17	Position of the drive shaft of the thread trimmer		14-16
14.18	Aligning the stop plate		14-17
14.19	Adjusting the trimmer solenoid.....		14-18
14.20	Adjusting the engaging lever.....		14-19
14.21	Position of the thread catcher and knife.....		14-20
14.22	Position of the release trip.....		14-21
14.23	Position of the release catch		14-22
14.24	Needle thread tension release		14-23
14.25	Thread check spring and thread regulator.....		14-24
14.26	Bobbin winder drive wheel		14-25
14.27	Work clamp initiator.....		14-26
14.28	Changing the work clamp		14-27

Contents

	Contents	Chapter-Page
BS 2903		
15	Proper use.....	15-1
16	Specifications.....	16-1
17	Control elements.....	17-1
17.01	Balance wheel	17-1
17.02	Level for adjusting the button clamp size	17-1
18	Setting up.....	18-1
18.01	Adjusting the size of the button clamp and sewing area.....	18-1
19	Input	19-1
19.01	Summary of the seam patterns.....	19-1
20	Adjustment.....	20-1
20.01	Aligning the button clamp	20-1
20.02	Button clamp height	20-2
20.03	Button clamp pressure	20-3
20.04	Changing the feeder and the jaws of the button clamp.....	20-4

BT 2900 / BS 2903

1 Safety

1.01 Directives

In addition to this Instruction Manual, also observe all generally accepted, statutory and other regulations and legal requirements and all valid environmental protection regulations!

The regionally valid regulations of the social insurance society for occupational accidents or their supervisory organizations are to be strictly adhered to!

1.02 General notes on safety

- This machine may only be operated by adequately trained operators and only after having completely read and understood the Instruction Manual!
- All Notes on Safety and Instruction Manuals of the motor manufacturer are to be read before operating the machine!
- The danger and safety instructions on the machine itself are to be followed!
- This machine may only be used for the purpose for which it is intended and may not be operated without its safety devices. All safety regulations relevant to its operation are to be adhered to.
- When exchanging sewing tools (e.g. needle, roller presser, needle plate and bobbin), when threading the machine, when leaving the machine unattended and during maintenance work, the machine is to be separated from the power supply by switching off the On/Off switch or by removing the plug from the mains!
- Everyday maintenance work is only to be carried out by appropriately trained personnel!
Repairs and special maintenance work may only be carried out by qualified service staff or appropriately trained personnel!
- Work on electrical equipment may only be carried out by appropriately trained personnel!
- Work is not permitted on parts and equipment which are connected to the power supply!
- Modifications and alterations to the machine may only be carried out under observance of all the relevant safety regulations!
- Only spare parts which have been approved by us are to be used for repairs! We expressly point out that any replacement parts or accessories which are not supplied by us have not been tested and approved by us. The installation and/or use of any such products can lead to negative changes in the structural characteristics of the machine. We are not liable for any damage which may be caused by non-original parts.

1.05 Operating and specialist personnel

1.05.01 Operating personnel

Operating personnel are persons responsible for the equipping, operating and cleaning of the machine as well as for taking care of problems arising in the sewing area.

The operating personnel is required to observe the following points and must:

- always observe the Notes on Safety in the Instruction Manual!
- never use any working methods which could adversely affect the safety of the machine!
- not wear loose-fitting clothing or jewellery such as chains or rings!
- also ensure that only authorized persons have access to the potentially dangerous area around the machine!
- always immediately report to the person responsible any changes in the machine which may limit its safety!

1.05.02 Specialist personnel

Specialist personnel are persons with a specialist education in the fields of electrics, electronics and mechanics. They are responsible for the lubrication, maintenance, repair and adjustment of the machine

The specialist personnel is obliged to observe the following points and must:

- always observe the Notes on Safety in the Instruction Manual!
- switch off the On/Off switch before carrying out adjustments or repairs, and ensure that it cannot be switched on again unintentionally!
- wait until the luminous diode on the control box is no longer blinking or on before beginning adjustment or repair work.
- never work on parts which are still connected to the power supply!
- replace the protective coverings and close the electrical control box after all repairs or maintenance work!

Safety

1.06 Danger



A working area of meter is to be kept free both in front of and behind the machine while it is in operation so that it is always easily accessible.



Never reach into the sewing area while sewing! Danger of injury by the needle!



Never leave objects on the table while adjusting the machine settings! Objects can become trapped or be slung away! Danger of injury!

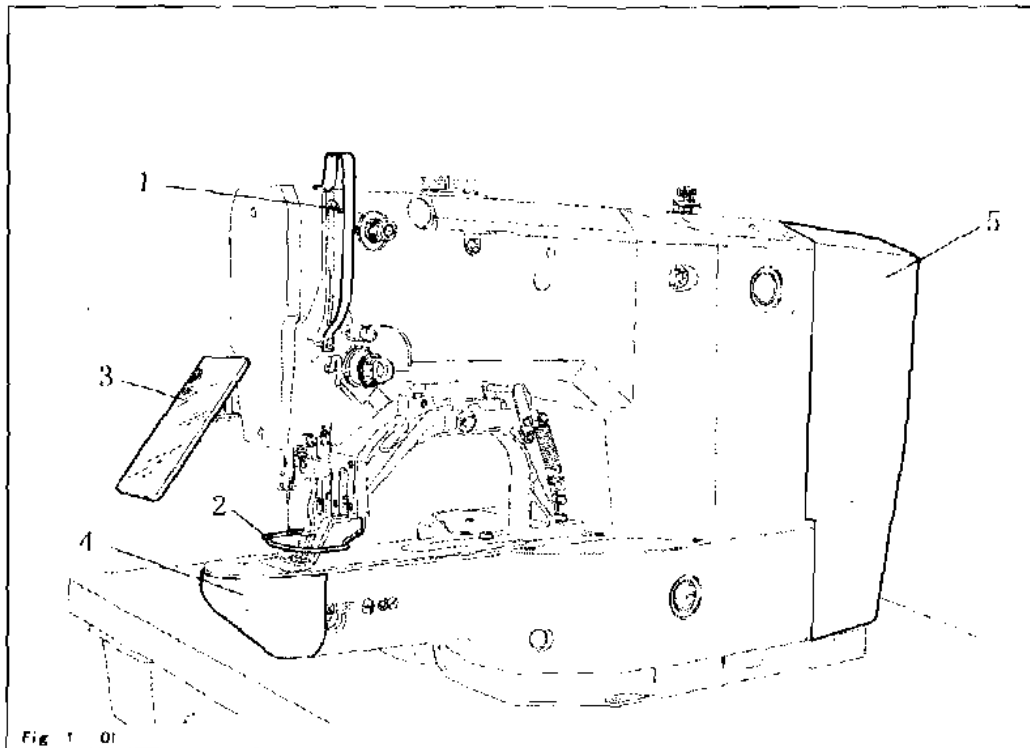

Fig. 1 01



Do not operate the machine without its take-up-lever guard 1!
Danger of injury due to the motion of the take-up lever!



Do not operate the machine without finger deflector 2!
Danger of injury by the needle!



Do not operate the machine without eye shield 3!
Danger of injury from flying needle fragments!



Only operate the machine with cover closed 4!
Danger of injury from rotating hook!



Do not operate the machine without cover 5!
Danger of injury from moving parts!

2 Proper use

The BT 2900 is an automatic sewing machine for sewing lockstitch bartacks and short seams in the sewing industry.



Any and all uses of this machine which have not been approved of by the manufacturer are considered to be inappropriate! The manufacturer cannot be held liable for any damage caused by the inappropriate use of the machine! The appropriate use of the machine includes the observance of all operational, adjustment, maintenance and repair measures required by the manufacturer!

Specifications

3 Specifications BT 2900

Sewing area:	X(lateral)direction 40mm Y(longitudinal)direction 20mm
Max. sewing speed:	※2700rpm(When sewing pitches are less than 4.5mm in X-direction and 3.5 mm in Y-direction.)
Sewing speed area:	400 to 2700 rpm
Stitch length:	0.1 to 10.0 mm
Feed type:	Intermittent feed
Stitch type:	301(lockstitch)
Needle bar stroke:	41.2 mm
Needle:	DP×5, DP×17(H)
Lift of work clamp foot:	13mm(standard) Max.17
Operating temperature range:	5°C to 35°C
Operating humidity range:	35% to 85%(No dew condensation)
Power supply:	220V±10%, 50/60Hz, single phase
Power consumption:	0.55kVA

Noise data:

Noise emission level at workplace

with a sewing cycle If 1 sec. on and 2 sec. off: 83dB(A)

Sewing head dimensions:

Length:	approx. 770 mm
Width:	approx. 220 mm
Height:	approx. 380 mm

Dimensions of standard base:

Length:	approx. 1060 mm
Width:	approx. 600 mm
Height:	approx. 820 mm

Weights:

Sewing head:	approx. 42 kilos
Base incl. control box:	approx. 45 kilos

※ Reduce the max. sewing speed in accordance with the sewing conditions.

▲ Subject to alterations

4 Disposal of machine

- The proper disposal of the machine is the responsibility of the customer.
- The materials used in the machines are steel, aluminium, brass and various plastics. The electrical equipment consists of plastics and copper.
- The machine is to be disposed of in accordance with the locally valid environmental protection regulations. If necessary, a specialist is to be commissioned.



Special care is to be taken that parts soiled with lubricants are separately disposed of in accordance with the locally valid pollution control regulations!

Transport, packaging and storage

5 Transport, packaging and storage

5.01 Transport to the customer' s premises

The machines are delivered completely packed.

5.02 Transport within the customer' s premises

The manufacturer bears no liability for transport within the customer' s premises or to the individual locations of use. Make sure that the machines are always transported upright.

5.03 Disposal of the packaging

The proper disposal of the packaging is the responsibility of the customer.

5.04 Storage

The machine can be stored for up to 6 months if not in use. During this time it should be protected from dust and moisture.

For longer storage the individual parts of the machine, especially the moving parts, must be protected from corrosion, e.g. by a film of oil

Explanation of the symbols

6 Explanation of the symbols

In the following section of this Instruction Manual, certain tasks or important pieces of information are accentuated by symbols.

The symbols used have the following meanings:



Note, information



Cleaning, care



Lubrication, greasing



Servicing, repairing, adjustment, maintenance
(only to be carried out by specialist personnel)

Control elements

7 Control elements

7.01 Main switch

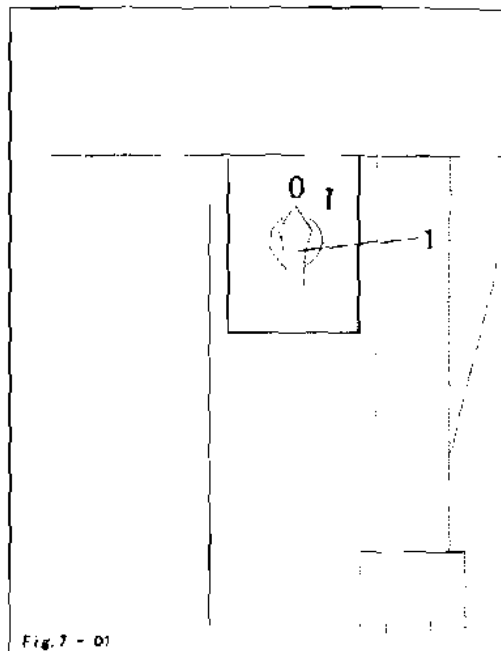

- Switch the machine on or off by turning main switch 1.



After switching the machine on, first press the „TE“ key to bring the machine into its neutral position.

7.02 Pedal

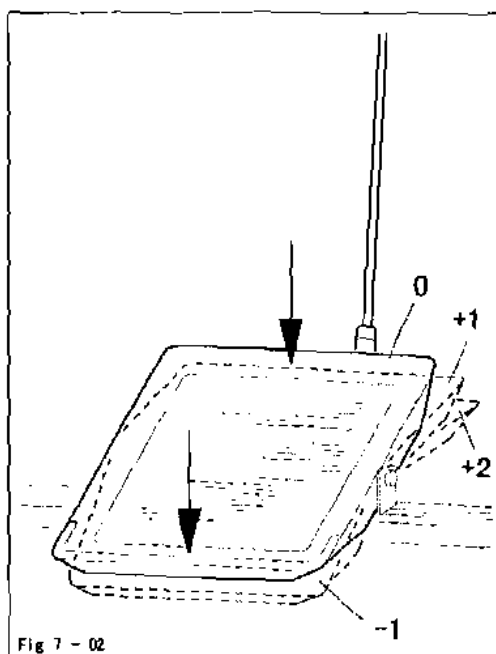

The pedal is used to lower and raise the work clamp, and to start the sewing program.

- 1 = sewing interruption
- 0 = neutral position
- +1 = lower work clamp
- +2 = sewing

7.03 Balance wheel

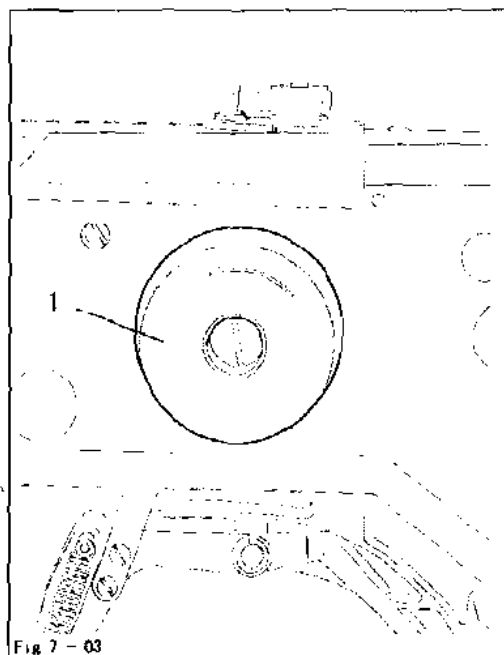



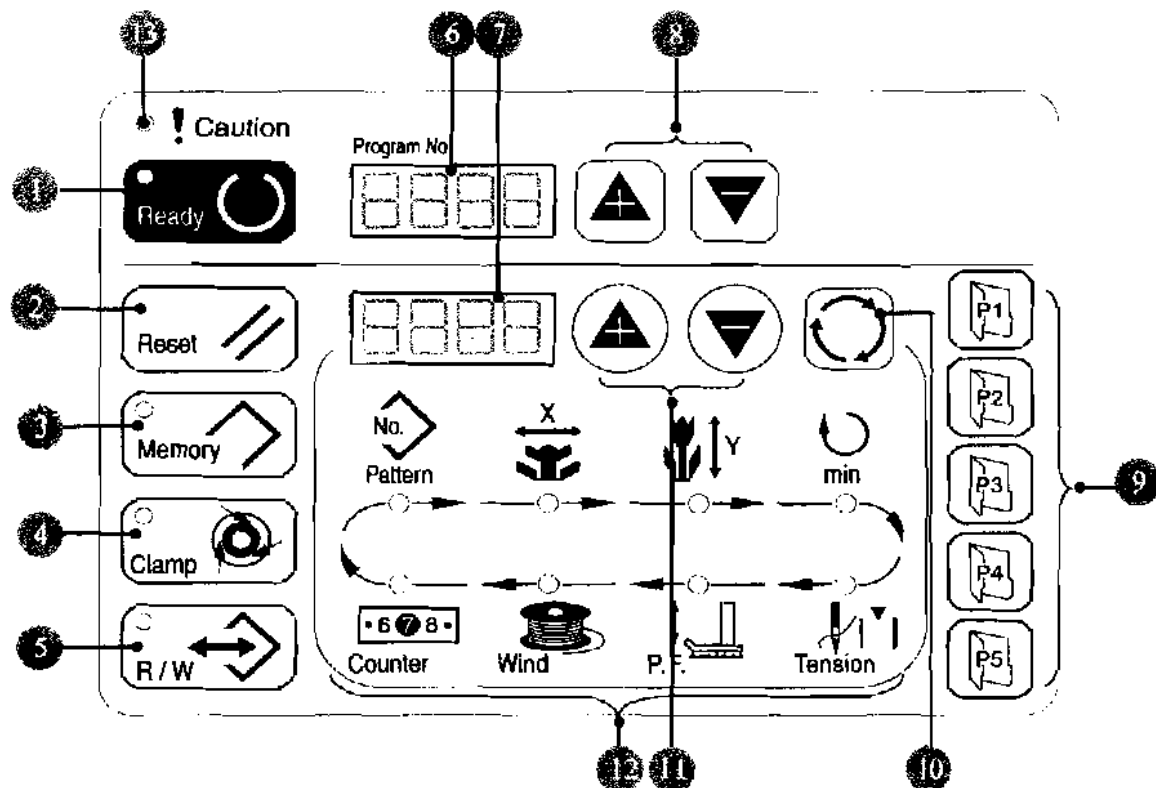

- By pressing and holding down balance wheel 1, it is possible to adjust the needle bar manually.

Control elements

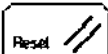

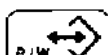
7.04 Description of operation panel





- 1**  Ready key
description: The LED goes off at the time of setting and lights up at the time of sewing state.
- 2**  Reset key
description: This key used for canceling error or returning the set value to initial value.
- 3**  Memory key
description: This key makes the setting mode of the memory switch.
- 4**  Clamp key
description: This key selects effective/ineffective of needle thread clamp. When it effective, needle thread clamp display LED light up.
- 5**  USB key
description: Uses USB to upload or down load data or pattern.
- 6**  Program No.
Upper window, parameters display
description: 4 digits LED display parameters code.



Control elements

- 



















Bottom window, parameter function & value display
 description: This 4 digit LED indicates the set value of the selected item such as  pattern no. X/Y scale, etc
- 

Parameter selected key
 description: This key uses for changing parameter code and forward/backward.
- 

Optional pattern key
 description: P1 ~ P5 is fast key for pattern selected but effective for pattern in data bank, P6
- 

Function select key
 description: Enter to pattern key , this key uses to select the function needed then uses  to change value.
- 

Value select key
 description: This key uses to change value of function & parameters.

-   Standard patterns (50)
-   X axis scale
-   Y axis scale
-   Speed of motor
-   Thread tension
-   Presser up/down
-   Bobbin winder
-   Sewing counter
-   Caution lamp

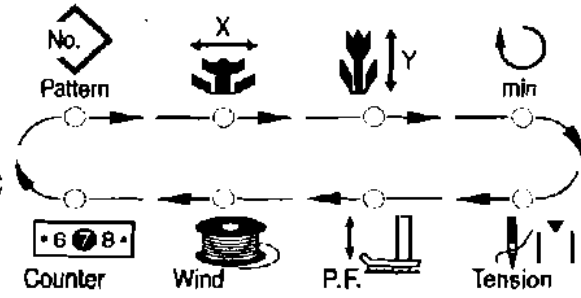

Push select key  to choice the mode you need, LED light up as the mode selected.

Installation and commissioning

8 Installation and commissioning

The machine must only be installed and commissioned by qualified personnel!

All relevant safety regulations must be strictly adhered to!



If the machine is delivered without a table, be sure to use a stand and table top that can hold the weight of the machine with its motor.

It is very important to ensure that the stand of the machine is firm and steady, also during sewing.

8.01 Installation

The site where the machine is installed must be provided with suitable connections for electric current.

It must be ensured that the standing surface of the machine site is firm and horizontal, and that sufficient lighting is provided for.



For packing and transportation reasons the table top is in the lowered position. The table height is adjusted as described below.



If the machine is delivered with stand, the transit lock must be removed before commissioning, see Chapter 8.01.02 Removing the transit lock.

8.01.01 Adjusting the table height

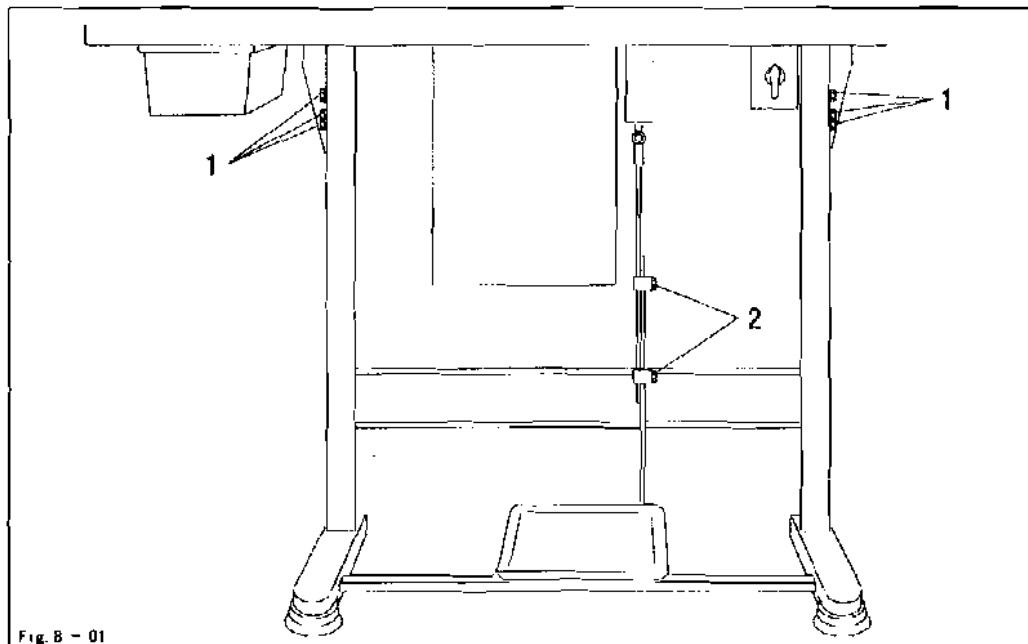
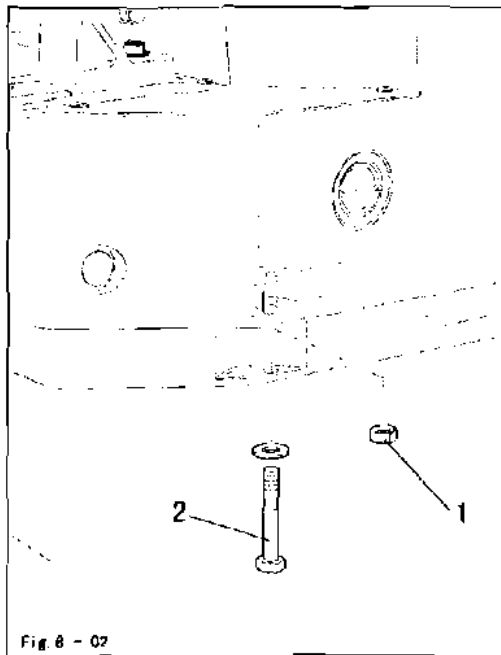

Fig. B - 01

- Loosen screws 1 and 2 and set the table height as required.
- Firmly tighten screw 1.
- Set the required pedal position and tighten screw 2.

8.01.02 Removing the transit lock



- Loosen nut 1.
- Remove screw 2.

8.01.03 Fitting the reel stand

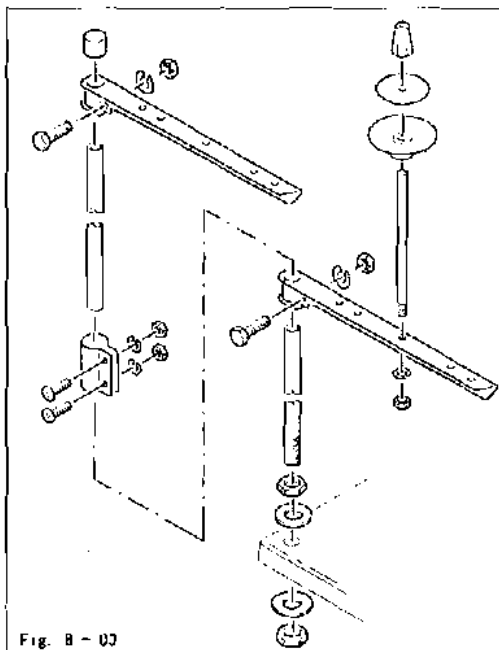

- Fit the reel stand as shown in Fig. 8 - 03
- Afterwards insert the stand in the hole in the table top and secure it with nuts provided.

Installation and commissioning

8.01.04 Mounting the table top (for deliveries without stand)

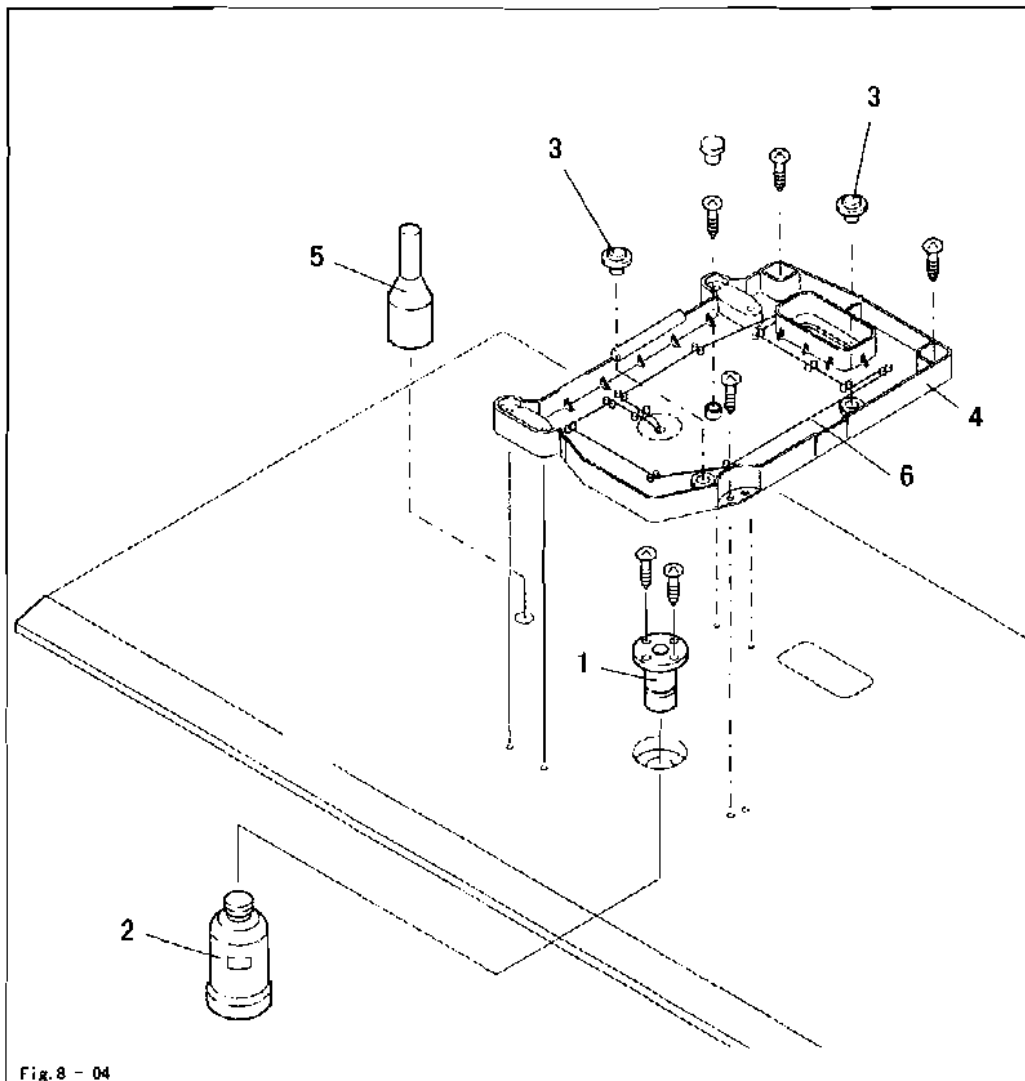
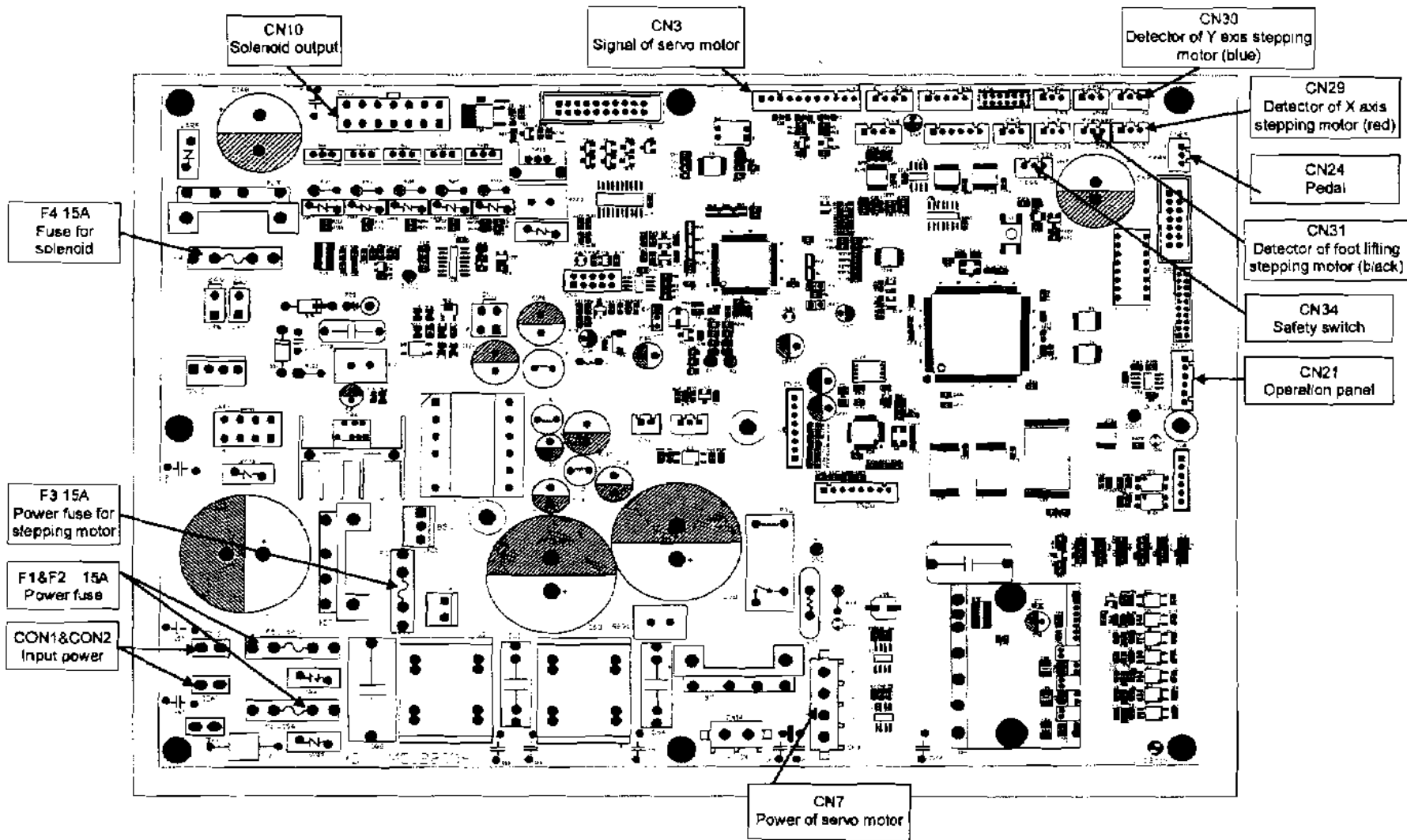

Fig.8 - 04

- Drill holes in the table top as shown in the drawing, see Chapter 8.01.05 Table top drill hole plans.
- Screw on the oil outlet 1
- Screw the oil tank 2 to oil outlet 1.
- Set the rubber pads 3 in the fastening holes of the oil pan 4 and screw oil pan 4 to the table top.
- Set support 5 in the appropriate hole.
- Place wick 6 in the holders of oil pan 4.

8.01.06-1 Connector Diagram of Main Board for stepping motor



8.01.06 Connecting the plug-in connections and earth cable

Installation and commissioning

Installation and commissioning

8.01.06-2 Connector diagram of driving board for stepping motor

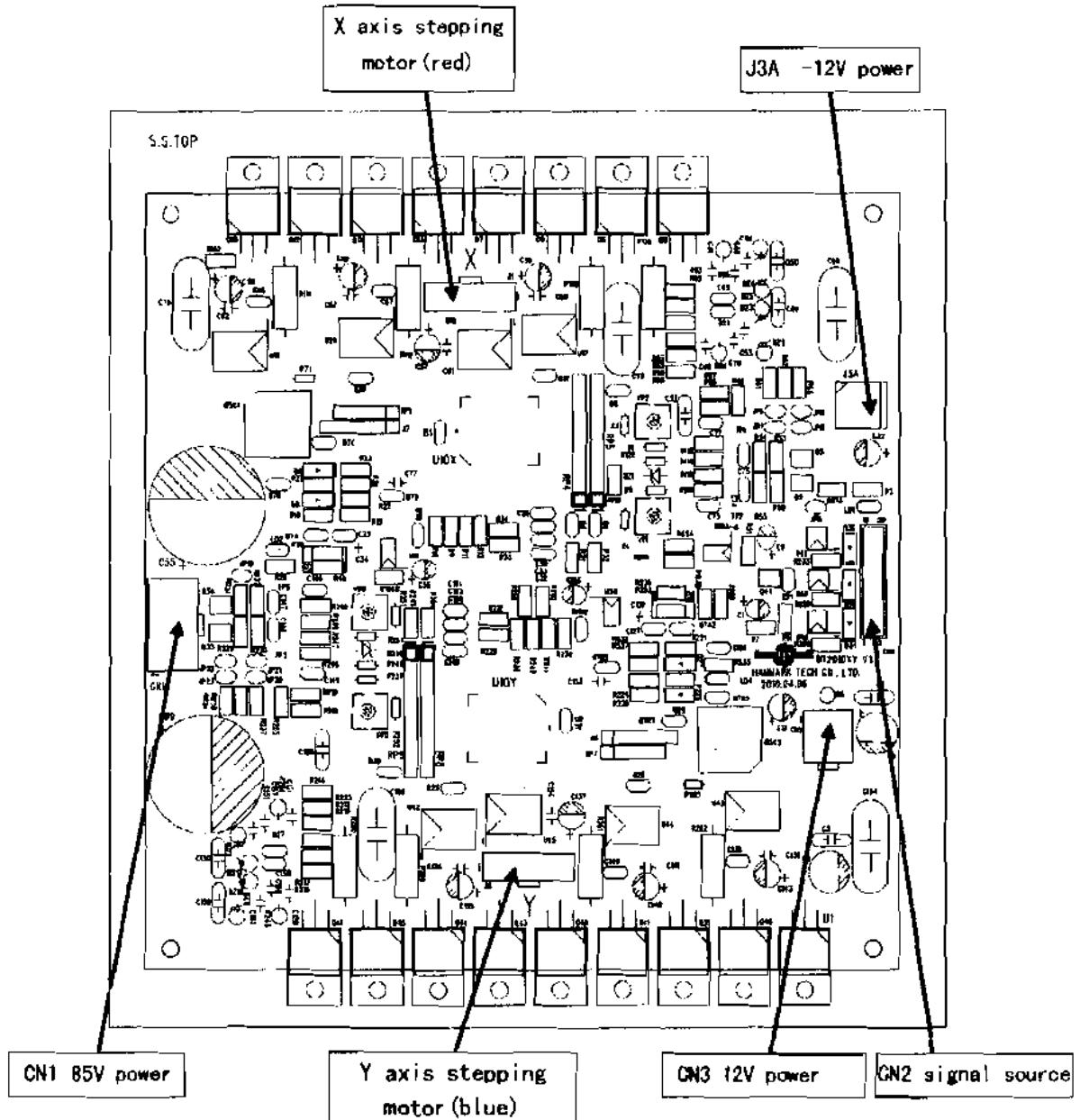

8.02 Commissioning the machine

- Clean the machine thoroughly.
- Check the oil level, see Chapter 12 Care and Maintenance.
- Check the machine, especially the electric wires, for any damage.
- Have specialists check, whether the machine's motor can be used with the existing mains voltage.

8.03 Switching the machine on/off

- Switching the machine on/off, see Chapter 7.01 Main switch.

Setting up

9 Setting up



All instructions and regulations in this instruction manual must be observed. Special attention must be given to all safety regulations!



All setting-up work must only be done by personnel with the necessary training. For all setting-up work the machine must be isolated from its power supply by turning off the on/off switch or removing the machine plug from the electric power socket!

9.01 Inserting the needle

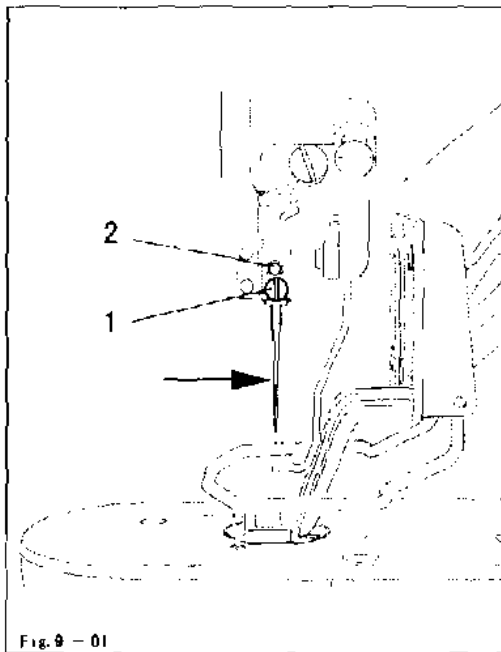

Switch off the machine!
Danger of injury if the machine is started accidentally!



Only use needles from the system intended for the machine, see Chapter 3 Specifications

- Loosen screw 1.
- Insert the needle as far as possible. The long needle groove (see arrow) must be facing forwards.
- Tighten screw 1.



Through hole 2 it is possible to check whether the needle has been inserted as far as possible.

Broken needles can be removed by inserted suitable tools in hole 2

9 02 Threading the needle thread / adjusting the needle thread tension

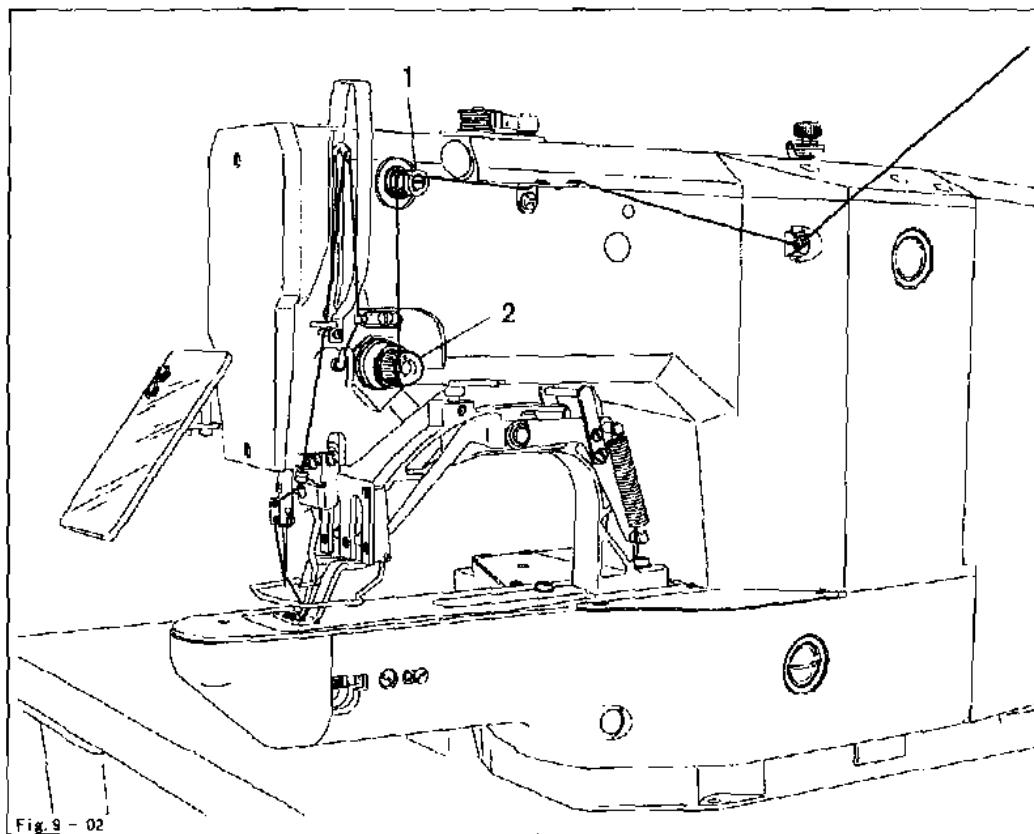

Switch off the machine!

Danger of injury if the machine is started accidentally!

- Thread the needle thread as shown in Fig. 9-02.
- Adjust the needle thread tension by turning milled nuts 1 and 2

Setting up

9 03 Winding the bobbin thread

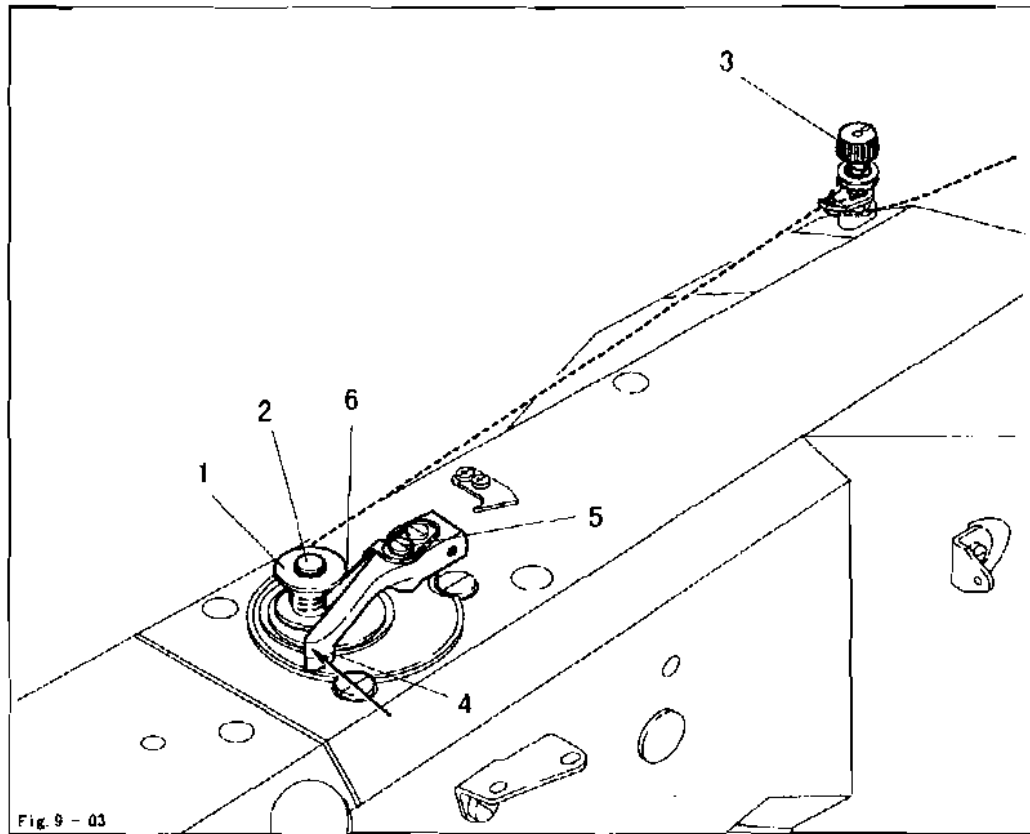

- Place the empty bobbin 1 on the bobbin winder spindle 2.
- Thread the thread as shown in Fig. 9-03 and wind it round bobbin 1 a few times in the anti-clockwise direction.
- Set the preliminary thread tension by turning milled screw 3.
- Press lever 4 in the direction of the arrow until it clicks into place.



The bobbin is filled during sewing.



- Winding is also possible as follows:
- Switch on the machine and press the key for winding.
- Remove the thread from the needle and take-up lever.
- Operate the pedal to carry out winding. the bobbin winder stops automatically as soon as the bobbin is adequately full.
- Press the key for winding. the machine stops.
- Thread the machine again.



Adjusting the amount of thread on the bobbin

- Loosen screw 5.
- Set stop 6 so that the bobbin winder switches off automatically when the thread is still ca. 1 mm from the edge of the bobbin.
- Tighten screw 5.

9.04 Removing / replacing the bobbin case

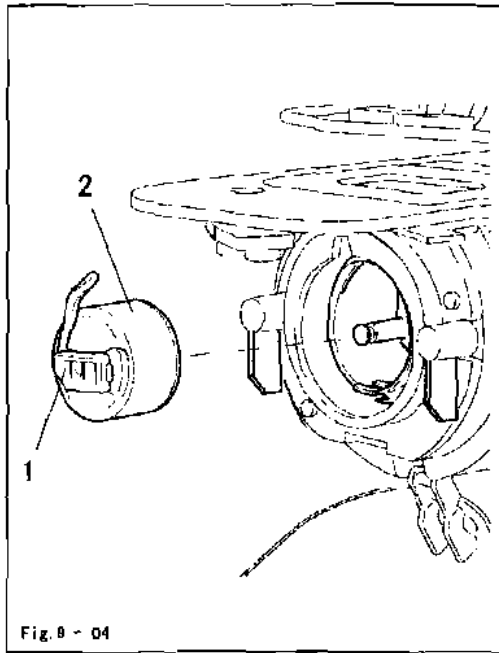

Switch off the machine.
Danger of injury if the machine starts accidentally!

Removing the bobbin case

- Open the hook cover
- Pull out latch 1
- Remove bobbin case 2

Replacing the bobbin case

- Push bobbin case 2 into the bobbin case base until you feel it click into place
- Close the hook cover.

9.05 Threading the bobbin thread / adjusting the bobbin thread tension

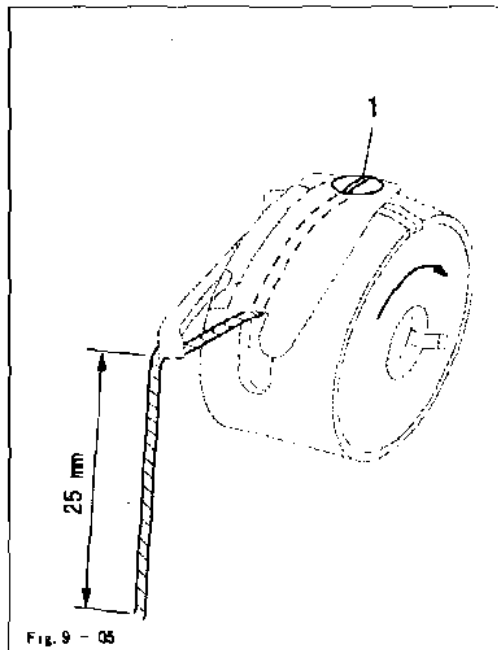



- Place the bobbin into the bobbin case, so that this turns in the direction shown by the arrow when the thread is pulled.
- Insert the thread as shown in Fig 9-05.
- Set the thread tension by turning screw 1.

Setting up

9.08 Performed setting of pattern sewing

1. Power ON bottom window display the pattern no.







This time  lamp in ready key is not light up, in case for sewing press  key and lamp light up, toe down  to start sewing, high heel for temporary stop at sewing on the middle way, toe down again to start sewing again.

Press  to get function you need while  lamp is not light up, procedure list below ..







Function description es below

2.  Setting of the pattern no.

Press  key to indicate the item "pattern no."  this time LED light up, then press   to choose   you need, it has 50 kind patterns (pleases refer to list of pattern), we reserve 10 blocks for constructing your own patterns, thus the display for pattern is: 0 ~ 50, P1 ~ P50, U01 ~ U10, it is no display if no pattern in block P&U.

※ Caution: Pattern choice must match the work clam foot, if not the needle will be broken.

3.  Setting of X scale

Press  key to indicate the item X scale  , then press   key to indicate the rate of enlargement or abstract, standard rate is 100.

※Caution: The setting exceeding 100% is dangerous, since needle and the cloth presser interferes with each other and needle breakage or the like will occur.





4.  Setting of Y scale

Press  key to indicate the item  Y scale this time LED light up, then





Press   to indicate the rate of enlargement or abstract, standard rate is 100.

※Caution: The setting exceeding 100% is dangerous, since needle and the cloth presser interferes with each other and needle breakage or the like will occur.









5.  Setting of max. sewing speed limitation

Press  key to indicate the item  speed of servo motor this time LED light up, then press   to indicete the speed, indicate 500 is set 500rpm.





6.  Setting the thread tension

Press  to indicate to item  this time LED light up, then press   to indicate the tension, the range is 0 ~ 200 normally set at 60.

7.  Function operation





The  gone out, only display function, but you can check the track of sewing at  the LED lights up, if you want to confirm the sewing track press  the LED lights up and the pedal depress  work clamp foot press, uses   key to move one stitch at same time bottom window displays the number of stitches, after confirmed press  key to lift up the work clamp foot, then press  LED gone out to perform next function setting.

8.  Setting of bobbin winding









Press  key to indicate bobbin winding, bottom window displays speed of winding, to start winding press  key, depress  to start running of servo motor, depress again to stop the sewing machine, finish setting press .

9.  Counter



9.1 setting & performed

Press  to indicate the counter  LED lights up and display stitches, press   to change stitches, press  revert to "0".
 ※counter has 2 kinds: positive (+) and minus (-), it must use with U020.
 ※counter can be set automatic stop, it must use with U076.

9.2 Setting of count from positive (+) and automatic stop

- a. Press  key the LED gone out.
- b. press  to select  LED lights up.
- c. uses   key to set times.
- d. press  key the LED lights up, press  key to show the times been set and sewing ready, after end of each sewing subtract one time till "0" then sewing stop, if you want to going on sewing press  to revert to the value been set.

10. Finish of setting

Press the  key, after the work clamp foot have moved and gone up, the sewing LED lights up, and the sewing is ready.
 ※After finish of setting, suggest to set at pattern for double check.
 ※Press  key to check the value been set under sewing but can not modify the value, if you have to modify press  key the LED gone out then modify.

Sewing

10 Sewing



The machine must be installed, connected and set up as described in Chapter 8 Installation and Commissioning.



The machine must not be operated without the safety devices 1 to 5. see Chapter 1.08 Danger warnings! Danger of injury!

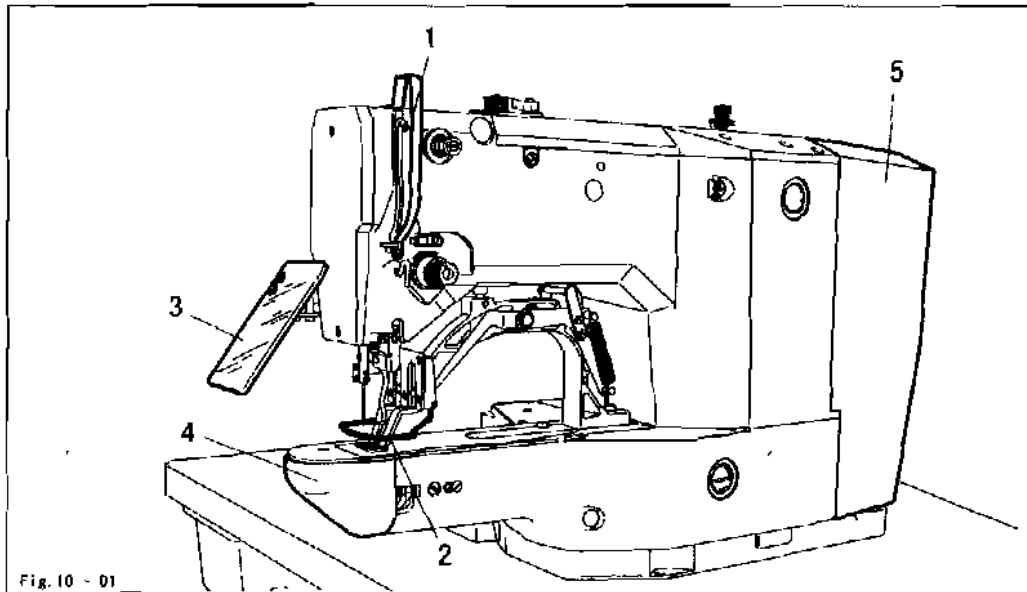

10.01 Operating cycle

- Carry out all steps in accordance with Chapter 9 Setting up.
- Place the material properly under the work clamp
- Lower the work clamp and start the sewing cycle, see Chapter 7.02 Pedal.

11 Input

11.01 Enter M1&M2 parameter zone and setting of pattern

1. Enter M1

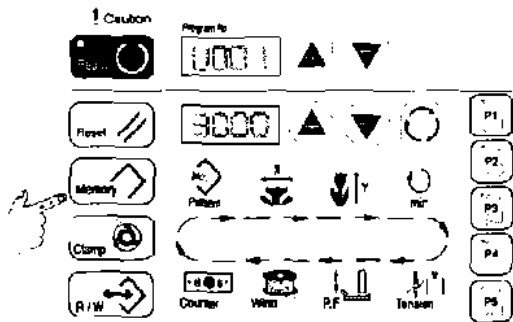

Ready key light off, press and hold 3sec. Hear one buzzer sound enter M1 zone and light up, upper window shows parameter code, bottom window shows the value of parameter, select parameter code press key, select value press To modify parameter value please press to select parameter code you want to change, bottom window shows the value of parameter, make sure you want to change. press light up, press to change the value of parameter, in case there is mistake on changing period, press key to cancel it and repeat the change, press key light off and press key wait light off to save, please process per above procedure if not the change only save temporary.

When shut off power and restart the parameter value revert to preset value.

2. Enter M2

While ready key light off press and hold 6 sec. Hear two buzzer sounds enter M2 zone.

3. Enter pattern setting

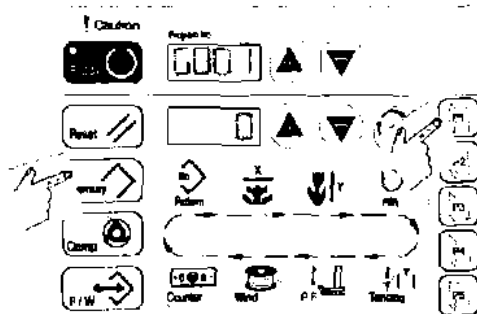

While ready key light off, press and P1 key to enter pattern setting, upper window shows pattern code, bottom window shows 0 or 1, 0 allows to setting, 1 is not allow to pattern setting, enter pattern setting press to select pattern, press to get 0 or 1.

Input

11.02 P key (Hot Key) Organization

1. How to access to P key setting mode

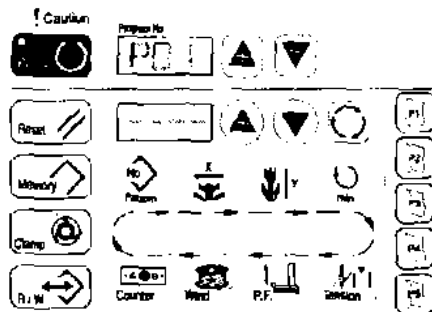

When key light off, press key and P2 key in the same time can access to P key setting mode, use upper display area to set P01~, lower area to choose pattern, For the first time will display as the left window, when you want to set up Hot Key function, use key to choose your favor Column as the Hot Key (P01 ~ P50 for selection). Then use key to select pattern, the procedure is as follow :

- pattern selection
- setting of the X scale
- setting of the Y scale
- setting of sewing speed
- setting of thread tension
- movement of X scale, unit: mm
- movement of Y scale, unit: mm

when all pattern detail set up, you need to press key with light off, then press key to leave P key setting mode. If you need to use any P key pattern you already registered (such as P1), just press P1 button.

※if you want to erase any P key setting, you have to access to P key setting mode, press key with light up, then press key to erase.

2. P key combination

Press P1~P5 button on the panel to access in P key setting mode, when selecting any P key after P6, it has to be perform by combination.

P No.	Selection key	P-No.	Selection key	P-No.	Selection key	P-No.	Selection key
P1	P1	P8	P1+P4	P15	P4+P5	P22	P2+P3+P4
P2	P2	P9	P1+P5	P16	P1+P2+P3	P23	P2+P3+P5
P3	P3	P10	P2+P3	P17	P1+P2+P4	P24	P2+P4+P5
P4	P4	P11	P2+P4	P18	P1+P2+P5	P25	P3+P4+P5
P5	P5	P12	P2+P5	P19	P1+P3+P4		
P6	P1+P2	P13	P3+P4	P20	P1+P3+P5		
P7	P1+P3	P14	P3+P5	P21	P1+P4+P5		

11.03 Group setting

1. How to access to sewing pattern group setting

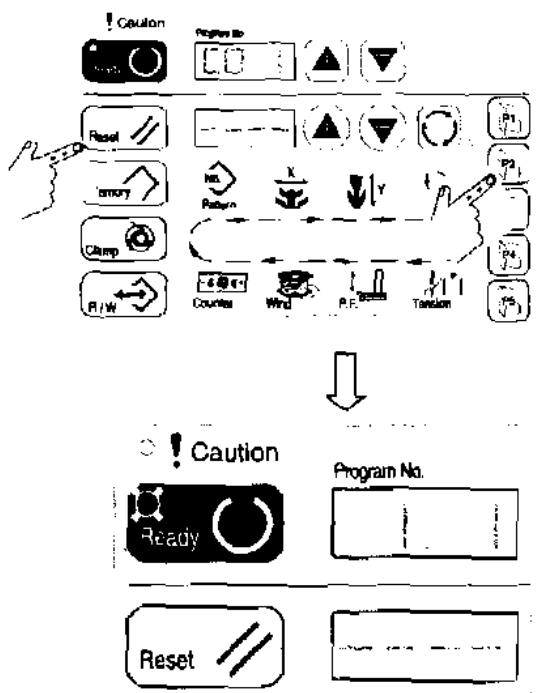

When key light off, press key and P3 key in the same time can access to group setting, use upper display area to set C01 ~ group, lower area to choose pattern, for the first time will display as the left window, when you want to set up Hot Key function, use key to choose your favor Column as the Hot Key (C01 ~ C25).

※ You have to organize P key area in advance

For example, if C01 group is selected, press key (light up) to access into group selection as the left picture, press key in lower display area to choose your favor first pattern, then use key in UPPER display area to select the second pattern (<1.2> displayed), again use in lower area to select pattern, upper area for the 3rd, 4th pattern, and end with key, after that, upper window will display the group code, and how many pattern you selected will be displayed on lower window, finally press key (light off) for finish.

※ If you want to erase the Hot Key setting, you have to access to group setting mode, press key to select group code, press key with light up, then press key to erase.

2. How to sewing with pattern group setting

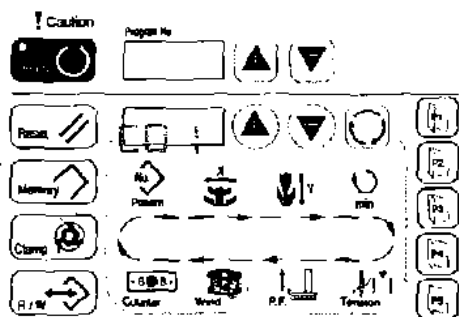

when key light off, use key in lower display area to select C01 as left picture.

Press key to confirm (light up).

Meanwhile, <1.1> displayed in upper window.

It means that this is the first pattern in C01 group, you can see P key number displayed in lower window, then you can press the pedal.

When the first pattern is finished, you will see <1.2> displayed in upper window, P key number displayed in lower window, the second pattern is ready to go.

If you want to use a certain pattern for one more time, press key to select it.

Input

11.04 Self-test & restore default

Self-test

1. How to access to Parameter Mode



press  key(light off)

hold  key for 6 seconds(light up),  key is still light off.

Indicate U100 with this key ▲ ▼

press  key,  key and  key will light off, then access into self-test mode

2. How to set self-test mode

 key should light off. use ▲ ▼ key and  key to access into each function..



: set sewing pattern



: set X-direction(crosswise) Size factor



: set Y-direction(lengthwise) Size factor



: set rotation speed



: set tension release



: constant stitch sewing



: set time Off timing (an interval stop timing between cycles)



: set how many cycle (Max:9999 X 10)

3. Start sawing

When all the detail set-up, press  key with light up, press pedal to star the auto self-test mode. heel the pedal for a temporary stop, step the pedal to continue sewing, heel the pedal twice when you want to end this model.

※ When self-test mode is set to be operated for a long time, origin retrieval modal is suggested as follow..

parameter: U029 = 2 (execution origin retrieval model every certain cycle)

parameter: U075 = 10 (execution origin retrieval model every certain 10 cycle)

11.05 Restore default

1. How to access to Parameter Mode

press  key(light off)

hold  key for 6 seconds(light up)

press ▲ ▼ key to set with U098

2. How to restore default

press  key(light off)

Indioate " 1 " with this key ▲ ▼

press  key, a beep sound mean restore to default settings, if beep for 3 times when it is failure.

11.06 Self-diagnosis I

1. Enter parameters zone

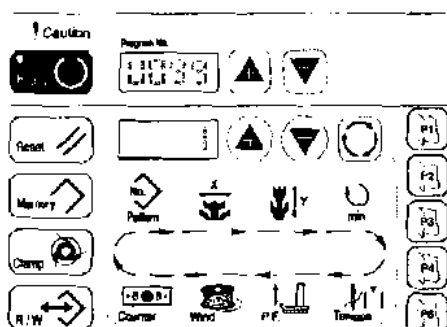

Press key (light off)

Press key, hold 6 sec. more (light up)

Press key, set at U099

Press key, clamp key blinking

2. Enter self-diagnosis

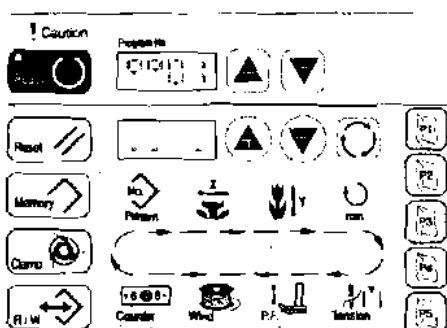

Press key, upper window shows different code, to process self-diagnosis ..

"01" : SENSOR working status, it shows by line spot, while the function is working the line spot blinking ..

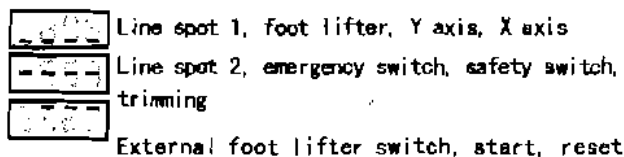

"02" : To identify the angle of servo motor, while turn the hand wheel bottom window shows position of angle: up position set at 12°, if uses this model for machine rectification please turn 360° then to up position (10° ~ 16°) and fix the coupling of motor and sewing machine.

"03" : Reserved.

"04" : Identify the position of pedal voltage.

"05" : Reserved.

"06" : Solenoid output, press key to select solenoid, press key to check solenoid working properly or not.

- 0 : tension release solenoid
- 1 : trimmer solenoid
- 2 : reserved
- 3 : needle thread clamp solenoid
- 4 : reserved
- 5 : foot lifter solenoid
- 6 : reserved
- 7 : solenoid in reserve
- 8 : wiper solenoid
- 9 : reserved

Input

11.07 Control box automatic detection II

2 Enter detection function

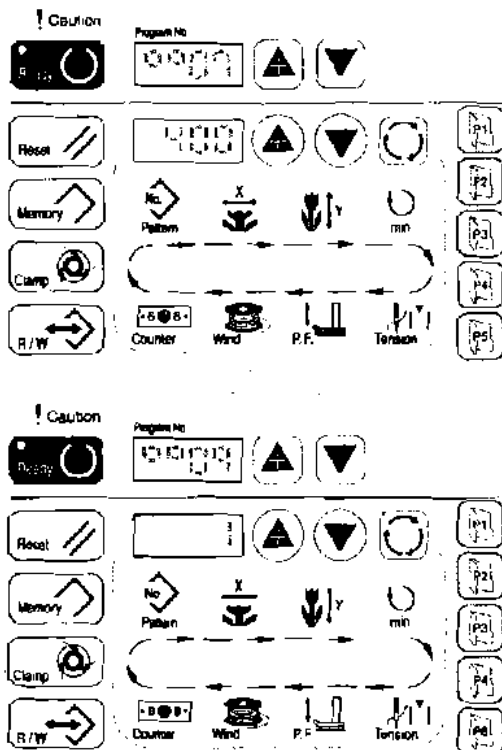



- " 07 " Detect the motor speed press ▲ ▼ to adjust speed, press ○ key to start and stop.
- " 08 " Reserved.
- " 09 " Press ▲ ▼ key for one step detect mode of X axis stepping motor at same time it identifies position of detector in X axis, the coupler blocks or leaves the position while " 1 " changes to " 0 ".
- " 10 " Multi step detect mode of X axis stepping motor, uses ▲ ▼ key and input number then press ○, press once ON/twice ON.
- " 11 " Press ▲ ▼ key for one step detect mode of Y axis stepping motor, at same time it identifies position of detector in Y axis, the coupler blocks or leaves the position while " 1 " changes to " 0 ".
- " 12 " Multi step detect mode of Y axis stepping motor, uses ▲ ▼ key and input number then press ○, press once ON/twice ON.
- " 13 " Press ▲ ▼ key for one step detect mode of presser foot lifting stepping motor, at same time it identifies position of detector in Y axis, the coupler blocks or leaves the position while " 1 " changes to " 0 ". Press ○ key to detect position points and setting parameters T020 ~T025.
- " 14 " Multi step detect mode for presser foot lifting stepping motor, uses ▲ ▼ input number and press ○ key once ON/twice ON.
- " 15 " Press ▲ ▼ key for one step test mode of thread clamp, it identifies 2 position of clamp detector, it is the coupler blocks or leaves position while " 1 " changes to " 0 ".
- " 16 " Setting PPS test for thread clamp stepping motor, uses ▲ ▼ input number and press ○ key once is ON direction. Escape press [Reset].
- " 17 " Origin point identifies function, the point uses to adjust coupler in X, Y axis detector. Operation mode set upper window at " 17 ", bottom window " 0 ", lamp [Clamp] is blinking, press ○ key blanking goes out, press foot down (origin point identifies & adjust), high heel to lift the work clamp foot and repeat. To stop press [Reset] key back to setting mode, [Clamp] blinking again. Escape press [Reset] key.
- " 18 " Origin identify function, this mode same as " 17 ", but work clamp foot at down position, escape press [Reset].
- " 19 " Origin identify function, this mode same as " 17 ", but work clamp foot at up position. Escape press [Reset].

11.08 Constructs your own pattern and the operation mode

1. Cancels the sewing mode

Press  key LED lamp goes out to cancel sewing mode.

2. Plug in USB

Plug in USB and you hear a "Buzzer" sound, press  key lamp light up enters to pattern edits mode, this time upper window display "U01", it means you can save your own pattern at U01 site, in case you plan to save to other sites please press   . it has 10 sites in system U01~U10.

3. Operation mode

Press  key lamp light up, upper window display "U01" (suppose saves in U01).

bottom window display "1". You can choose 1 ~ 4 in bottom window.





1: edited pattern down load to control box through USB.

2: edited pattern down load to USB from control box (one lot only).





3: deletes edited pattern in control box.

4: edits pattern by press   &  key in operation panel.





a. " 1: edited pattern down load to control box through USB "

Press   key to get bottom window at " 1 ", press  key down load pattern to control box, at this time " 1 " disappear few seconds then re-display, press  key window show the total stitches and saves pattern into U01.

b. " 2: edited pattern down load to USB from control box (one lot only) "



Press   key to get bottom window at " 2 ", press  key down load pattern to USB from control box, press  key to save.

c. " 3: deletes edited pattern in control box "

Press   key to get bottom window at " 3 ", press  key to delete, press  Key to identify delete completed, bottom window shows " - - - - - ".

Note! Please double check before delete.

d. " 4: Edits pattern by press   &  key in operation panel "

d.1. Press   key to get bottom window at " 4 ".

d.2. Press  key enters to edit mode, at this time upper window displays " 1 ", it is first stitch, bottom displays " | | - - - " it is X axis please input the coordinate of first stitch, if press

 key it changes to the coordinate of first stitch of Y axis, the Symbol is " | - - - | ", press

  key to input coordinate value.

d.3. While first stitch completed press   to get 2nd stitch, operation same as d.2.

d.4. edits completed press  key to save in selected U site.

d.5. press again  key LED lamp goes out, bottom window displays total stitches of edited pattern, for example the total stitches list below is 5 stitches.

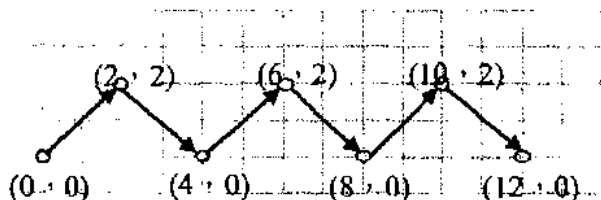

Input

11.09 How to edit your own pattern (U01 ~ U10)

1. Pattern editing (uses Autocad or other softwares)

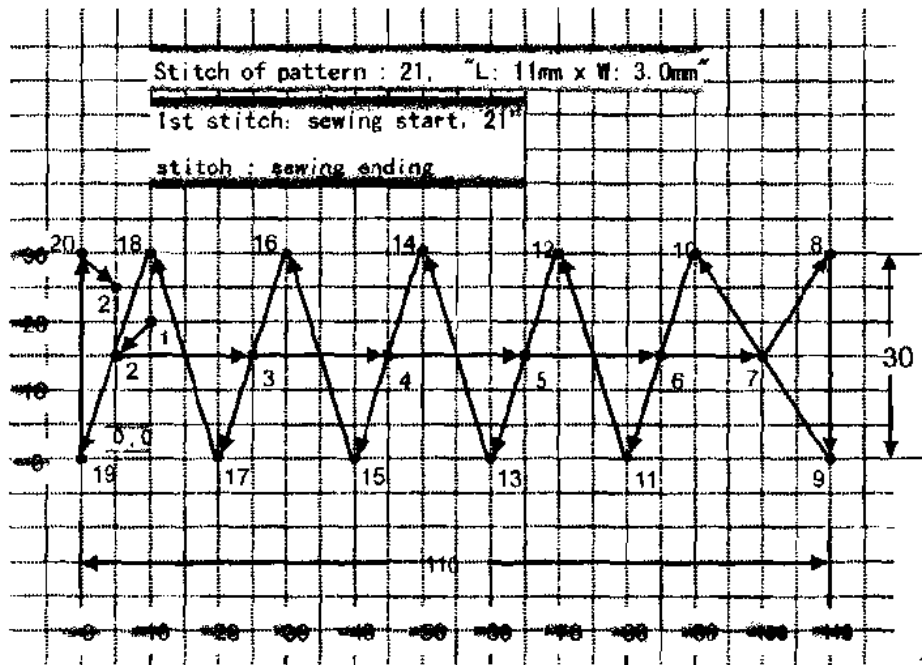

2. Sets coordinate point

stitch	X base	Y base	stitch	X base	Y base
1	10	20	16	30	30
2	5	15	17	20	0
3	25	15	18	10	30
4	45	15	19	0	0
5	65	15	20	0	30
6	85	15	21	5	25
7	100	15			
8	110	30			
9	110	0			
10	90	30			
11	80	0			
12	70	30			
13	60	0			
14	50	30			
15	40	0			

3. Uses "identify input coordinate file form" to confirm correct coordinate value.
4. Gives a file name to edited pattern: HSR2000.CSV and save to USB.
5. Plug in USB to USB port which in control box, press and key which on upper window to choose the storage area (U01 ~ U10), set "1" of bottom window by at same time press key to down load pattern in USB (HSR2000.CSV) to the area selected.

11.10 Identify input coordinate file form

Value of Coordinate	
X axis	Y axis
10	20
5	15
25	15
45	15
65	15
85	15
100	15
110	30
110	0
90	30
80	0
70	30
60	0
50	30
40	0
30	30
20	0
10	30
0	0
0	30
5	25

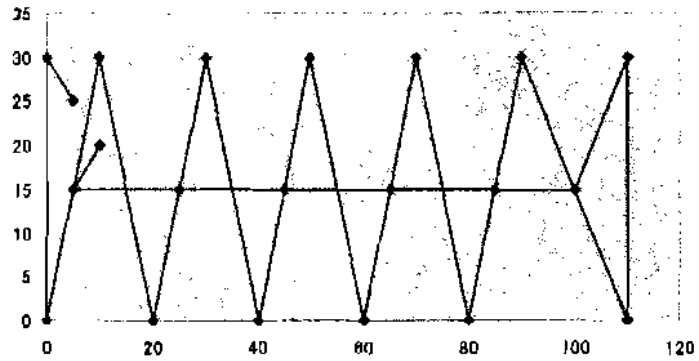

11.11 HSR2000.CSV file form

10	20
5	15
25	15
45	15
65	15
85	15
100	15
110	30
110	0
90	30
80	0
70	30
60	0
50	30
40	0
30	30
20	0
10	30
0	0
0	30
5	25

stitch	X axis	Y axis	stitch	X axis	Y axis
1	10	20	16	30	30
2	5	15	17	20	0
3	25	15	18	10	30
4	45	15	19	0	0
5	65	15	20	0	30
6	85	15	21	5	25
7	100	15			
8	110	30			
9	110	0			
10	90	30			
11	80	0			
12	70	30			
13	60	0			
14	50	30			
15	40	0			

Input

11.12 Table of the standard patterns]

No.	Stitch Diagram	Number of Stitches	Lengthwise	Crosswise	Sewing Type
1		42	16	2	Large Patterns
2			10	2	
3			16	2.5	
4			24	3	
5		28	10	2	
6			16	2	
7		36	10	2	
8			18	2.5	
9		56	24	3	
10		64	24	3	
11		21	6	2.5	Small Patterns
12		28	6	2.5	
13		36	6	2.5	
14		14	8	2	Knitting Patterns
15		21	8	2	
16		28	8	2	
17		21	10	0	Linear Patterns
18		28	10	0	
19			25	0	
20		36	25	0	
21		28	4	20	Lengthwise Patterns
22		36	4	20	
23		42	4	20	
24		56	4	20	
25		28	4	20	
26		38	4	20	

11.12 Table of the standard patterns II

No.	Stitch Diagram	Number of Stitches	Lengthwise	Crosswise	Sewing Type
27		18	0	20	Lengthwise Patterns
28		21	0	10	
29			0	20	
30		26	0	20	
31		52	10	7	Semi lunar Patterns
32		63	12	7	
33		24	10	6	
34		31	12	6	
35		48	7	10	
36					
37		90	24	3	Large Patterns
38		28	8	2	Knitting Patterns
39		28	Ø12		Round Patterns
40		48			
41		29	20	2.5	Lengthwise Patterns
42		39	25	2.5	
43		45	25	2.5	
44		58	30	2.5	
45		75	30	2.5	
46		42	30	2.5	
47		91	Ø8		Radial Patterns
48		99			
49		148			
50		164			

Input



11.13 Parameters List

Operation Mode	Display				Content			Mode	Preset	
	GROUP	CODE	Function	Range	Description / Note	Bar tacking Machine	Button Sewing Machine			
1. Press M key 3 seconds (for M1 mode)	U	0 0 1	Minimum sewing speed	400 - 3000	Minimum speed adjustment. speed can be set in a unit of 100rpm	M1	2700	2500		
	U	0 0 2	With needle thread clamp, sewing speed of 1 st stitch		sewing speed adjustment. speed can be set in a unit of 100rpm	M1				
	U	0 0 3	With needle thread clamp, sewing speed of 2 nd stitch		Sewing speed adjustment. speed can be set in a unit of 100rpm	M1				
	U	0 0 4	With needle thread clamp, sewing speed of 3 rd stitch		Sewing speed adjustment. speed can be set in a unit of 100rpm	M1				
2. Press M key 6 seconds	U	0 0 5	With needle thread clamp, sewing speed of 4 th stitch		Sewing speed adjustment. speed can be set in a unit of 100rpm	M1				
	U	0 0 6	With needle thread clamp, sewing speed of 5 th stitch		Sewing speed adjustment. speed can be set in a unit of 100rpm	M1				
	U	0 0 7	With needle thread clamp, Thread tension of 1 st stitch			M1				
	U	0 0 8	Stitches of thread clamp	1 ~ 7	Number of stitches that needle thread clamp releases is set	M1	2	2		
	U	0 0 9	Clamping timing of needle thread clamp can be delayed	- 10 ~ 0	Timing is delayed in 1/10 second	M1	0	0		
	U	0 1 0	Thread tension at the time of thread trimming	0 ~ 200		M1	0	0		
	U	0 1 1	Changover timing of thread tension at the time of thread trimming	- 6 ~ 4	Tension and trimming timing adjustment	M1	0	0		
	U	0 1 2	Without needle thread clamp, sewing speed of 1 st stitch	400 - 1500	sewing speed adjustment. speed can be set in a unit of 100rpm	M1	400	400		
	U	0 1 3	Without needle thread clamp, sewing speed of 1 st stitch	400 - 3200	sewing speed adjustment. speed can be set in a unit of 100rpm	M1	900	700		
	U	0 1 4	Without needle thread clamp, sewing speed of 1 st stitch	400 - 3200	sewing speed adjustment. speed can be set in a unit of 100rpm	M1	1800	1400		
	U	0 1 5	Without needle thread clamp, sewing speed of 1 st stitch	400 - 3200	sewing speed adjustment. speed can be set in a unit of 100rpm	M1	2700	2500		
	U	0 1 6	Without needle thread clamp, sewing speed of 1 st stitch	400 - 3200	sewing speed adjustment. speed can be set in a unit of 100rpm	M1	2700	2500		
	U	0 1 7	Without needle thread clamp, thread tension of 1 st stitch	0 - 200		M1	0	0		
	U	0 1 8	Changover timing of 1 st stitch (without needle thread clamp)	- 5 ~ 2	Active angle = 60 - 4 * U018	M1	- 5	- 5		
	U	0 1 9	Sewing whether or not indication or change of pattern No. XY scale rate and max. thread friction is acceptable (Prevention of misapplication)	0/1	0: Operative, 1: Inoperative Note: in case of setting 1, use of M key is prohibited as well. When changing memory switch. Pressing M key, turn on the power switch.	M1	0	0		
	U	0 2 0		0/1		M1	0	0		
	U	0 2 1	Counter operation	0/1/2	0: production counter (adding), 1: bobbin thread counter (subtracting)	M1	0	0		
	U	0 2 2	Selection of pedal	50-80	0: standard pedal, 1: standard pedal (2-step stroke), 2: optional pedal	M1	70	70		
	U	0 2 3	Height of work clamp box at the time of 2 step stroke	0/1	Effect while parameter D2 (step at 2 step stroke)	M2	0	0		
	U	0 2 4	Seeding sewing alert at change of pattern XY scale rate	0/1/2	0: origin, 1: sewing start point	M1	1	1		
	U	0 2 5	Sewing machine operation can be stopped with pedal key (Reset)	0/1/2	0: inoperative, 1: pedal reset key, 2: external switch	M1	2	2		

Operation Mode	Display				Content	Mode	Preset			
	<input type="checkbox"/>	<input type="checkbox"/>	<input type="checkbox"/>	<input type="checkbox"/>			Bar tacking Machine	Button Sewing Machine		
	GROUP	CODE							Function	Range
	U	0	2	6	Needle thread clamp control can be prohibited (thread clamp switch can be set)	0/1	0 : normal : 1 : prohibited	M1	1	1
	U	0	2	7	Feed timing is selected when stitches are not well tightened, set the value in " " direction (only effect at exceed 1100rpm)	-8 ~ 16	Per unit 4 %, setting on excessive " " side may cause needle breaking. Be careful when sewing heavy weight material (only effect at exceed 1100rpm)	M1	12	12
	U	0	2	8	State of work clamp foot after completion of sewing can be selected	0/1	0 : work clamp foot goes up after moving at sewing start 1 : work clamp foot goes up by pedal operation after moving at sewing start	M1	0	0
	U	0	2	6	Execution of origin retrieval every time after completion of sewing can be performed	0/1/2	0 : without origin retrieval : 1 : with origin retrieval : 2 : can set times but must perform with U075	M1	0	0
	U	0	3	0	Setting of origin retrieval in cycle stitches can be set	0/1/2	0 : without origin retrieval : 1 : every time 1 pattern is completed : 2 : every time 1 cycle is completed	M1	0	0
	U	0	3	1	State of work clamp foot when machine stopped by temporary stop command can be selected	0/1/2	0 : work clamp foot goes up : 1 : work clamp foot goes up with work clamp foot switch : 2 : lift of work clamp foot is prohibited	M1	2	2
	U	0	3	2	Needle bar stop position is set	0/1	0 : up position : 1 : upper dead point (reserve at up position)	M1	0	0
	U	0	3	3	Thread trimming can be prohibited	0/1	0 : normal : 1 : thread trimming prohibited (except trimming at emergency stop)	M2	0	0
	U	0	3	4	Route of origin return by means of clear key can be selected	0/1	0 : straight line return : 1 : reverse return of pattern	M2	0	0
	U	0	3	5	Bobbin winding speed can be set	800 - 2000	Max. speed limitation has priority, speed can be set in a unit of 100 rpm	M1	1800	1600
	U	0	3	6	Wiper operation method can be selected	0/1	0 : without wiper at the time of thread trimming on the way : 1 : with wiper at the time of thread trimming on the way	M1	1	1
	U	0	3	7	Timing of work clamp foot solenoid ms	5 - 500	Full - Time can be set	M2	60	60
	U	0	3	8	Timing of work clamp foot solenoid Duty-Cycle %	1 - 30	Duty cycle can be set, in case voltage under 200V please increase time.	M2	18	18
	U	0	3	9	Timing of trimming solenoid ms	5 - 500	Full - Time can be set	M1	200	200
	U	0	4	0	Trimming speed can be set (2 stepping motor)	100 - 700	Unit: RPM	M1	300	300
	U	0	4	1	Angle of trimming (up position is base point)	180 - 250	Angle from down position (Lo → H) at trimming	M1	180	180
	U	0	4	2	Height of work clamp foot (only effect for stepping motor type)	0 - 30	"0" most height point of work clamp foot	M2	0	0
	U	0	4	3	+ X limited range of moving (right side)	-99 ~ 99 mm	Limited by work foot size Unit: mm	M2	20	20
	U	0	4	4	- X limited range of moving (right side)	-99 ~ 99 mm	Limited by work foot size Unit: mm	M2	-20	-20
	U	0	4	5	+ Y limited range of moving (right side)	-99 ~ 99 mm	Limited by work foot size Unit: mm	M2	10	10
	U	0	4	6	- Y limited range of moving (right side)	-99 ~ 99 mm	Limited by work foot size Unit: mm	M2	-10	-10
	U	0	4	7	Reserved ID			M2	0	0
	U	0	4	8	Reserved ID			M2	0	0
	U	0	4	9	Location of work foot switch (speed control unit) at standard pedal	50 ~ 200		M2	100	100
	U	0	5	0	Location of start switch (speed control unit) at standard pedal	30 ~ 200		M2	185	185
	U	0	6	1	Location of Hi Lo stroke switch at standard pedal	30 ~ 200		M2	140	140

Input

Operation Mode	Display				Content				Mode	Preset	
	GROUP	CODE	Function	Range	Description / Note	Bar tacking Machine	Burton Sewing Machine	Mode			
								Bar tacking Machine		Burton Sewing Machine	
	U	0 5 2	Speed of work foot drop down at pedal performed	100 - 4000pps	Unit: pps	M2	4000	4000			
	U	0 5 3	Speed of work foot rise up at pedal performed	100 - 4000pps	Unit: pps	M2	4000	4000			
	U	0 5 4	Speed of work foot rise up at trimming after sewing ending	100 - 4000pps	Unit: pps	M2	2400				
	U	0 5 5	Work foot rise up can be set after sewing completed	0/1	0 : work foot rise up after sewing completed 1 : work foot is not rise up after sewing completed and keep sewing	M2	0	0		0	
	U	0 5 6	Trimming speed can be set (3/4 stepping motor)	400 - 800	RPM	M2	400	400		400	
	U	0 5 7	Reserved IO	0/1		M2	1	1		1	
	U	0 5 8	emergency stop by pedal	0/1	0 : ineffective : 1 : effective	M2	0	0		0	
	U	0 5 9	Feed performed	0/1/2	0 : prohibited : 1 : performed at work foot drop down 2 : performed at sewing start	M2	0	0		0	
	U	0 6 0	Timing of zipper	10 - 500ms	Unit: ms	M2	80	80		80	
	U	0 6 1	Timing of zipper return	10 - 500ms	Unit: ms	M2	100	100		100	
	U	0 6 2	Delay time of double-Trimming	100-400	Unit: ms	M2	150	150		150	
	U	0 6 3	Trimming can be set	0/1	0 : trimming performed : 1 : prohibited (trimming is not performed at emergency stop), it is ineffective even 033 set at trimming performed	M2	0	0		0	
	U	0 6 4	Origin can be set after sewing completed	0/1	0 : sewing start point : 1 : origin	M1	0	0		0	
	U	0 6 5	Reserved IO	0/1		M2	0	0		0	
	U	0 6 6	Reserved IO	0/1		M2	0	0		0	
	U	0 6 7	XY feed speed (speed from origin to sewing start point)	100 - 4000pps	Unit: pps	M2	2000	2000		2000	
	U	0 6 8	XY speed of feed forward / backward (one step execution & Reset)	100 - 4000pps	Unit: pps	M2	500	500		500	
	U	0 6 9	Power ON - READY key selected	0/1	0 : power on and press READY key : 1 : power ON and READY key performed	M2	0	0		0	
	U	0 7 0	Select lock current of servo motor at UP position	0/1	0 : locked : 1 : unlocked	M2	1	1		1	
	U	0 7 1	Reserved IO	30 - 60		M2	45	45		45	
	U	0 7 2	Safety switch	0/1	0 : normally closes : 1 : normally open	M1	1	1		1	
	U	0 7 3	Thread clamp solenoid FK1	20 - 340	Solenoid ON at 20 degree of up position	M2	20	20		20	
	U	0 7 4	Thread clamp solenoid FK2	10 - 700	Angle of clamp performed : must do with clamp switch	M2	80	80		80	
	U	0 7 5	Times of origin return	1 - 100	Effective at parameter UD28 sets * 2	M1	100	100		100	
	U	0 7 6	Counter stop automatically - must do with UD20 - U100	0/1	0 : effective : 1 : ineffective	M1	1	1		1	
	U	0 7 7	Sewing speed changes can be set	0/1	0 : constant speed : 1 : speed changed, performed with TD40-T046	M2	0	0		0	
	U	0 7 8	Reserved IO			M2	0	0		0	
	U	0 7 9	Reserved IO			M2	0	0		0	

Operation Mode	Display				Content			Mode	Pre-set	
	<input type="checkbox"/>	<input type="checkbox"/>	<input type="checkbox"/>	<input type="checkbox"/>	Function	Range	Description / Note		Bar tacking Machine	Button Sewing Machine
	GROUP	CODE								
	U	0	8	0	Reserved I/O			M2	0	0
	U	0	8	1	Speed of 1 st stitch count from the end	400 - 1800	Unit RPM	M2	1300	1300
	U	0	8	2	Speed of 2 nd stitch count from the end	400 - 3200	Unit RPM	M2	1800	1800
	U	0	8	3	Speed of 3 rd stitch count from the end	400 - 3200	Unit RPM	M2	2300	2300
	U	0	8	4	Speed of 4 th stitch count from the end	400 - 3200	Unit RPM	M2	2800	2800
	U	0	8	5	Reserved I/O			M2	0	0
	U	0	8	6	Reserved I/O			M2	0	0
	U	0	8	7	Reserved I/O			M2	0	0
	U	0	8	8	Reserved I/O			M2	0	0
	U	0	8	9	Reserved I/O			M2	0	0
	U	0	9	0	Accumulated times of trimming at normal sewing	0-99999999	Accumulated times of trimming at normal sewing	M2+USB	0	0
	U	0	9	1	Limitation of sewing time	0/1	0: effective ; 1: ineffective	M2+USB	1	1
	U	0	9	2	Value of limitation of sewing time	0 - 9999	unit per hour	M2+USB	0	0
	U	0	9	3	Accumulated sewing time	0 - 9999	unit per hour	M2+USB	0	0
	U	0	9	4	Reserved I/O			M2	0	0
	U	0	9	5	Current curve of Tension can be set	0/1	0: curve a ; 1: curve b	M2	0	0
	U	0	9	6	PLA of servo motor		Unit degree	M2	11	11
	U	0	9	7	Version of software		press   to find the version of main board, operation panel, drive board, Pattern	M2		
	U	0	9	8	Back to factory pre-set value	0/1	0: ineffective ; 1: effective	M2	0	0
	U	0	9	9	Test automatic mode	0/1		M2		
	U	1	0	0	Sewing automatic mode	0/1		M2		

Operation Mode	Display				Content			Mode	Preset	
	<input type="checkbox"/>	<input type="checkbox"/>	<input type="checkbox"/>	<input type="checkbox"/>					Bar tacking Machine	Button Sewing Machine
	GROUP	CODE			Function	Range	Description / Note			
Press M key + P1 key	G	0	0	0	Register pattern performed	0/1	0 : can be read · 1 : can not be read	M + P1	0	0
	G	0	0	1	Register pattern performed 1	0/1	0 : can be read · 1 : can not be read	M + P1	0	0
	G	0	0	2	Register pattern performed 2	0/1	0 : can be read · 1 : can not be read	M + P1	0	0
	G	0	0	3	Register pattern performed 3	0/1	0 : can be read · 1 : can not be read	M + P1	0	0
	G	0	0	4	Register pattern performed 4	0/1	0 : can be read · 1 : can not be read	M + P1	0	0
	G	:	:	:	:	:	:	M + P1	:	:
	G	:	:	:	:	:	:	M + P1	:	:
	G	:	:	:	:	:	:	M + P1	:	:
	G	1	3	0	Register pattern performed 130	0/1	0 : can be read · 1 : can not be read	M + P1	0	0
Press M key + P2 key	P	0	1		Constructs your own pattern subject to standard pattern P1		Press select key then do as the instruction in panel (blank at initial)	M + P2		
	P	0	2		Constructs your own pattern subject to standard pattern P2		Press select key then do as the instruction in panel (blank at initial)	M + P2		
	P	0	3		Constructs your own pattern subject to standard pattern P3		Press select key then do as the instruction in panel (blank at initial)	M + P2		
	P	0	4		Constructs your own pattern subject to standard pattern P4		Press select key then do as the instruction in panel (blank at initial)	M + P2		
	P	0	5		Constructs your own pattern subject to standard pattern P5		Press select key then do as the instruction in panel (blank at initial)	M + P2		
	:	:	:		:		:	M + P2		
	P	5	0		Constructs your own pattern subject to standard pattern P50		Press select key then do as the instruction in panel (blank at initial)	M + P2		
	U	0	1		Constructs your own pattern U1 (total 10 units)			M + P2		
	U	0	2		Constructs your own pattern U2			M + P2		
	U	0	3		Constructs your own pattern U3			M + P2		
	:	:	:		:		:	M + P2		
	U	1	0		Constructs your own pattern U10			M + P2		
Press M key + P3 key	C	0	1		Constructs your own cycle patterns C1 (mostly 30 units P or U)		Press select key then do as the instruction in panel (blank at initial)	M + P3		
	C	0	2		Constructs your own cycle patterns C2 (mostly 30 units P or U)		Press select key then do as the instruction in panel (blank at initial)	M + P3		
	C	0	3		Constructs your own cycle patterns C3 (mostly 30 units P or U)		Press select key then do as the instruction in panel (blank at initial)	M + P3		
	:	:	:		:		:	M + P3		
	C	2	5		Constructs your own cycle patterns C25 (mostly 30 units P or U)		Press select key then do as the instruction in panel (blank at initial)	M + P3		

Input

11.14 7-Segment display characters compare table:

Arabic Numerals:

Actual	0	1	2	3	4	5	6	7	8	9
Display	0	1	2	3	4	5	6	7	8	9

English Alphabet:

Actual	A	B	C	D	E	F	G	H	I	J
Display	A	B	C	D	E	F	G	H	I	J
Actual	K	L	M	N	O	P	Q	R	S	T
Display	K	L	M	N	O	P	Q	R	S	T
Actual	U	V	W	X	Y	Z				
Display	U	V	W	X	Y	Z				

Input

11.15 Error code and corrective measure

When error happens, an error code will be displayed and lightening, in while, this key will  lighten in red as below, the error code and corrective measure is as follow.

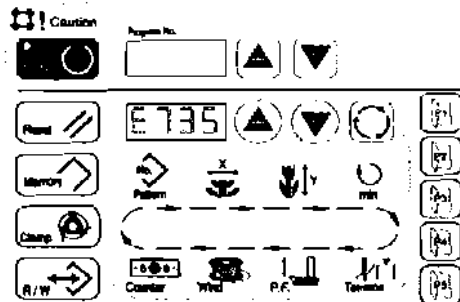

Display	Code Message	Status	Measurement
EB	Reserved correcting table error	Reserved correcting table reading error.	Download the table list data again.
E10	Pattern number error	Back-up pattern No. has not been registered in the data ROM. Or it is set to readout inoperative. Pattern No is set to 0 .	Press the RESET key, confirm the pattern No is not 0, check the data ROM.
E30	Needle position error	Needle bar is out of the needle up position.	1. check all the wire connections 2. turn the hand pulley to return the needle bar to the UP position.
E40	Sewing area over	The sewing area is beyond the limit	Press the RESET key, check the pattern and X/Y scale rate.
E42	Enlargement error	The sewing pitch is beyond 10mm.	Press the RESET key, check the pattern and X/Y scale rate.
E45	Pattern data error	The pattern data cannot be adopted.	Press the RESET key, check the data ROM.
E60	Temporary stop	Temporary stop by operating the reset key while the sewing machine is running.	Re-start or return-to-origin after thread trimming by means of the reset key.
E302	Head tilt error	Head tilt detection SW is turned OFF.	The sewing machine can not be operated with the head tilted, return the sewing machine head to its proper position.
E305	Thread trimmer position error	The thread trimmer is not in the proper position.	Turn off the power SW, check sensor.
E306	Needle thread clamp position error	The needle thread clamp device is not in the proper position.	Turn off the power SW, check sensor.
E332	Foot lifter position error	The foot lifter is not in the proper position.	Turn off the power SW, check sensor.
E501	Data reading error	The saving data is not save in this file or not exist.	Re-copy this file and save to USB disk.
E502	USB disk reading error	MOT file data error, cannot read.	Re-copy this file and save to USB disk.
E503	SUM check error	CHECKSUM data failure in MOT file.	Re-copy the CHECKSUM file and save to USB disk.
E504	END BLOCK ERROR	There is no END BLOCK data in the MOT file.	Re-copy the END BLOCK file and save to USB disk.

Display	Code Message	Status	Measurement
E505	USB reading ERROR	The USB disk is not found.	Turn off the power SW; insert the disk after the system is ready.
E506	USB reading ERROR	Reading U01~U10 failure.	Turn off the power SW; insert the disk after the system is ready.
E507	User's own pattern reading error	U01~U10 reading failure.	Download the data again.
E508	User's own pattern file type error	U01~U10 reading failure.	Re-check the data type.
E509	User's own pattern data out of limit	U01~U10 reading failure.	Re-check the data type.
E510	User's own pattern data out of limit, or "0"	U01~U10 reading failure.	Re-check the data type, or download the data again.
E511	USB disk re-writing error	The same file name already exists.	Erase the old file or re-name.
E512	USB reading error	Cannot download the data from USD disk.	Re-check the USB disk.
E513	USB disk write-in error	Cannot copy the data to USD disk.	Re-check the USB disk.
E550	Data writing error	Flash memory write-in error.	Turn off the power SW, re-start the procedure, or you have to exchange with a new board.
E551	Internal process error	Error from software internal process failure.	Turn off the power SW, re-start the procedure, or you have to exchange with a new board or up-date the software.
E707	Motor signal error	Motor stopped, or encoder A/B cannot be detected.	Check motor or encoder.
E735	Motor signal error	Motor stopped, or encoder A/B cannot be detected.	Check motor or encoder.
E736	Motor rotation error	After some time, motor stopped or encoder A/B cannot be detected.	Check motor or encoder.
E737	Z phase detected error	After some time, Z phase signal does not change	Check motor or encoder.
E738	Z phase detected error	After some time, Z phase signal does not detect the appointed angle, or encoder A/B cannot be detected.	Check motor or encoder.
E907	X origin retrieval error	X origin sensor does not change	Turn off the power SW, check sensor
E908	Y origin retrieval error	Y origin sensor does not change	Turn off the power SW, check sensor
E910	Foot lifter origin retrieval error	Foot lifter origin sensor does not change	Turn off the power SW, check sensor
E911	Foot lifter motor error	Foot lifter motor stops working.	Turn off the power SW, check driver, motor and wire connection.
E913	Needle tread clamp origin retrieval error	Foot lifter origin sensor does not change	Turn off the power SW, check sensor
E914	Needle tread clamp motor error	Needle tread clamp motor stop working.	Turn off the power SW, check driver, motor and wire connection.

Care and maintenance

12 Care and maintenance

12.01 Maintenance intervals

Clean the entire machine.....	once a week
Clean the hook compartment..	once a day, more often when in continuous operation
Oiling the needlehead parts.....	as required
Oiling the hook.....	as required
Oiling the bearing points in the arm.....	once a month



During all cleaning work the machine must be disconnected from the power supply by switching off the main switch or pulling out the plug!

Danger of injury if the machine is started accidentally!

12.02 Cleaning the machine

The cleaning cycle required for the machine depends on following factors:

- Single or several shift operation
- Amount of dust resulting from the workpiece

It is therefore only possible to stipulate the best possible cleaning instructions for each individual case.



For all cleaning work the machine must be disconnected from the mains by switching off the on/off switch or by removing the mains plug!

Danger of injury if the machine suddenly starts up.



To avoid breakdowns, the following cleaning work is recommended for single shift operation:

- Clean hook compartment and needle area of sewing head several times daily.
- Clean the entire machine at least once a week.

12.03 Cleaning the hook compartment

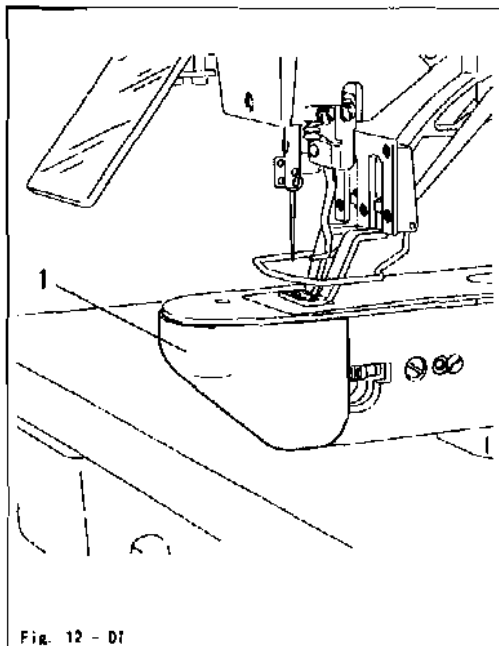

Fig. 12 - D7



Switch off the machine!

Danger of injury if the machine is started accidentally!

- Open the hook compartment cover 1.
- Clean the hook and the hook compartment daily, more often if in continuous operation.

12.04 Oiling the needle head parts

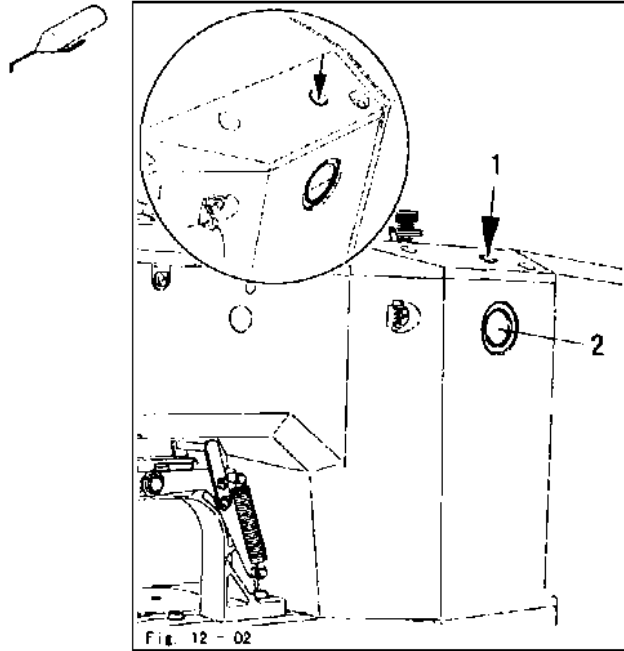

- When required, pour oil through hole 1 up to the upper marking in inspection glass 2



Only use oil with a mean viscosity of $10.0 \text{ mm}^2/\text{s}$ at 40°C and a density of 0.847 g/cm^3 at 15°C .

12.05 Oiling the hook

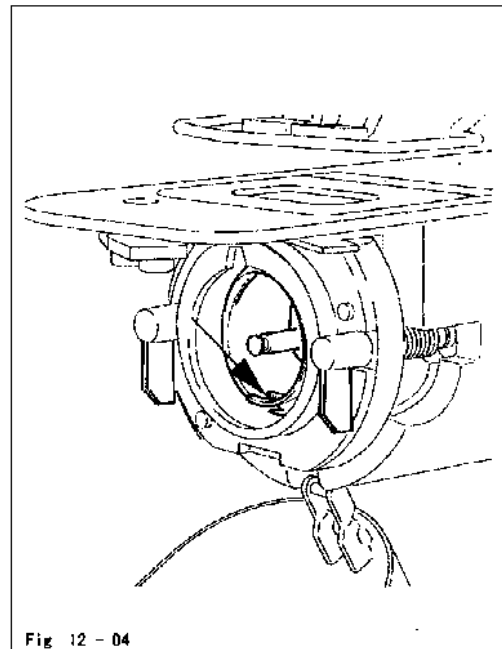
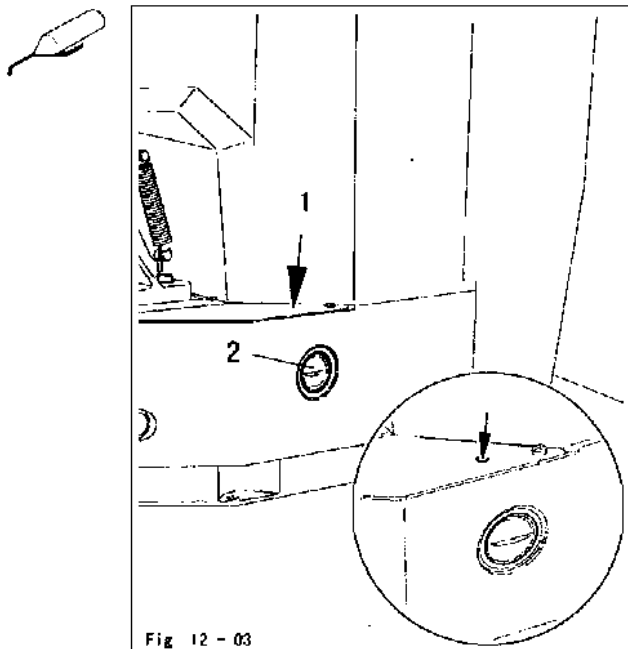

Switch off the machine!
Danger of injury if the machine is started accidentally!

- When required, pour oil through hole 1 up to the upper marking in inspection glass 2
- Before commissioning the machine, and after long downtimes, also add a few drops of oil to the hook race, see arrow in Fig. 12-04.



Only use oil with a mean viscosity of $10.0 \text{ mm}^2/\text{s}$ at 40°C and a density of 0.847 g/cm^3 at 15°C .

Care and maintenance

12.06 Oiling the bearing points in the arm

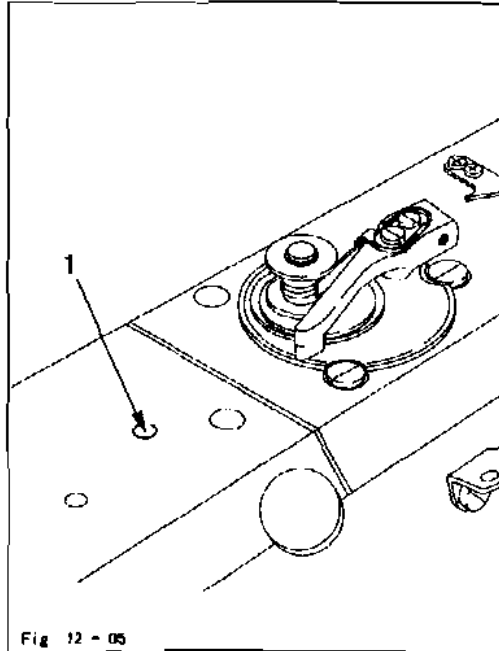

- Once a month pour a few drops of oil into hole 1.



Only use oil with a mean viscosity of 10.0 mm²/s at 40 and a density of 0.847 g/cm³ at 15.

12.07 Oil disposal

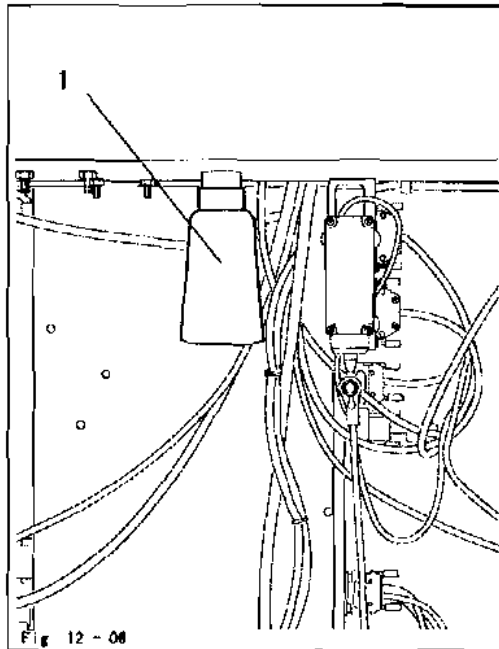

- When required, unscrew oil collector and dispose of the oil in accordance with the valid local environmental regulations.



The oil must not get into the sewer system! Danger of damage to the environment!

13 **Operation for particular patterns**



For sewing particular patterns, Please make parts replacement!

Adjustment

14 Adjustment



Please observe all notes from **Chapter 1 Safety** of the instruction manual! In particular care must be taken to see that all protective devices are refitted properly after adjustment, see **Chapter 1.06 Danger warnings** of the instruction manual!



If not otherwise stated, the machine must be disconnected from the electrical power supply.

14.01 Notes on adjustment

All following adjustments are based on a fully assembled machine and may only be carried out by expert staff trained for this purpose.

Machine covers, which have to be removed and replaced to carry out checks and adjustments, are not mentioned in the text!

The order of the following chapters corresponds to the most logical work sequence for machines which have to be completely adjusted. If only specific individual work steps are carried out, both the preceding and following chapters must be observed.

Screws, nuts indicated in brackets () are fastenings for machine parts, which must be loosened before adjustment and tightened again afterwards.

14.02 Tools, gauges and other accessories

- 1 set of screwdrivers with blade widths from 2 to 10 mm
- 1 set of spanners with jaw widths from 7 to 14 mm
- 1 set of Allen keys from 1.5 to 6 mm

14.03 Abbreviations

t.d.c. = top dead centre

b.d.c. = bottom dead centre

14.04 Explanation of the symbols

In this adjustment manual, symbols emphasize operations to be carried out or important information. The symbols used have the following meaning:



Note, information



Service, repair, adjustment, maintenance
(work to be carried out by qualified staff only)

14.05 Basic position of the machine

Requirement

After the machine has been switched on, it should position in t.d.c. needle bar.

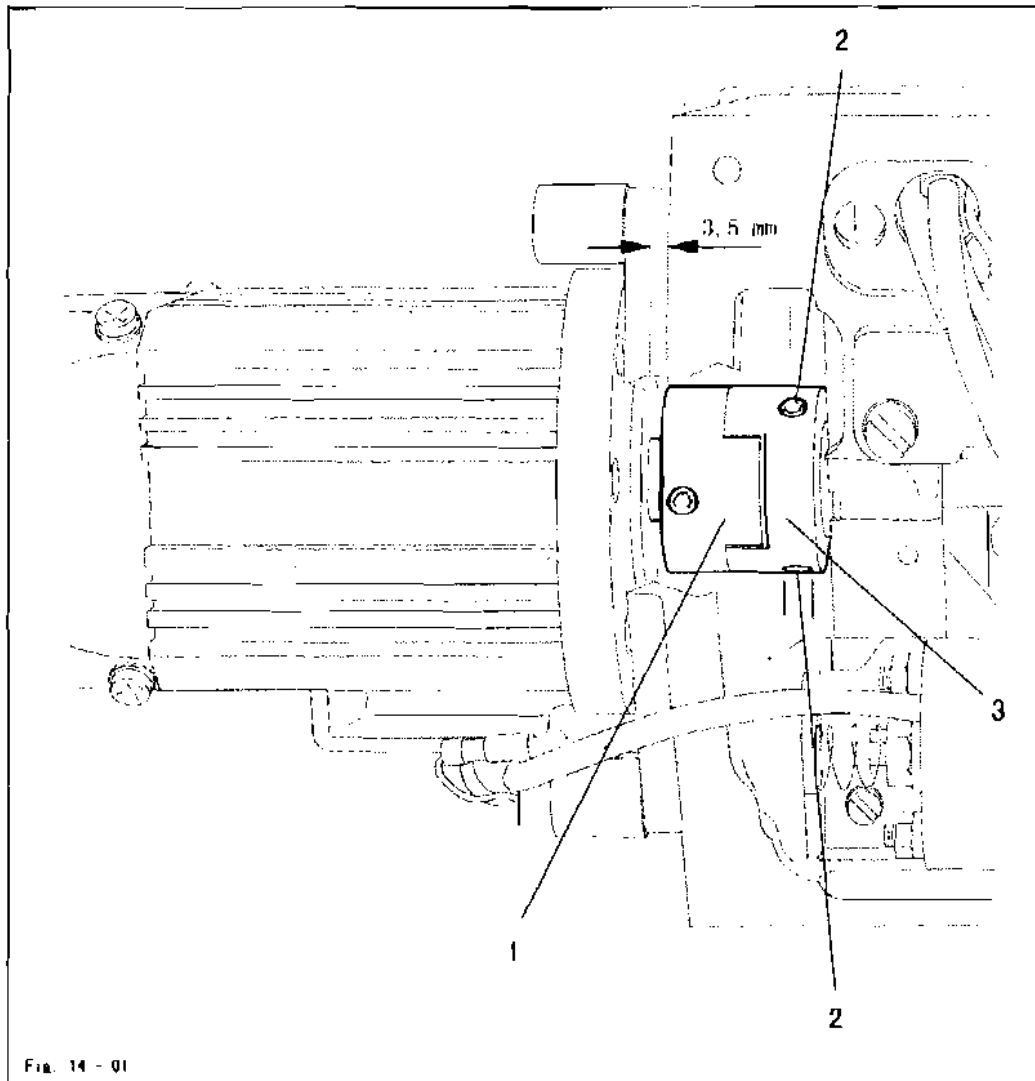

- Switch on the machine.
- Hold clutch (screws 2) and bring the needle bar into the appropriate position by turning the balance wheel.
- Switch off the machine.

The distance from the clutch 1 to the motor plate should be 3.5 mm.

In the direction of rotation the second screw of the clutch section 3 should be on the surface of the motor shaft.

The clutch section should be touching the O-ring of the axial bearing.

Adjustment

14.06 Work clamp zero point

Requirement

After the machine has been switched on

1. the needle should be centred to the hole in the adjustment gauge.
2. the switch lugs 2 and 4 should be centred to the respective initiator.

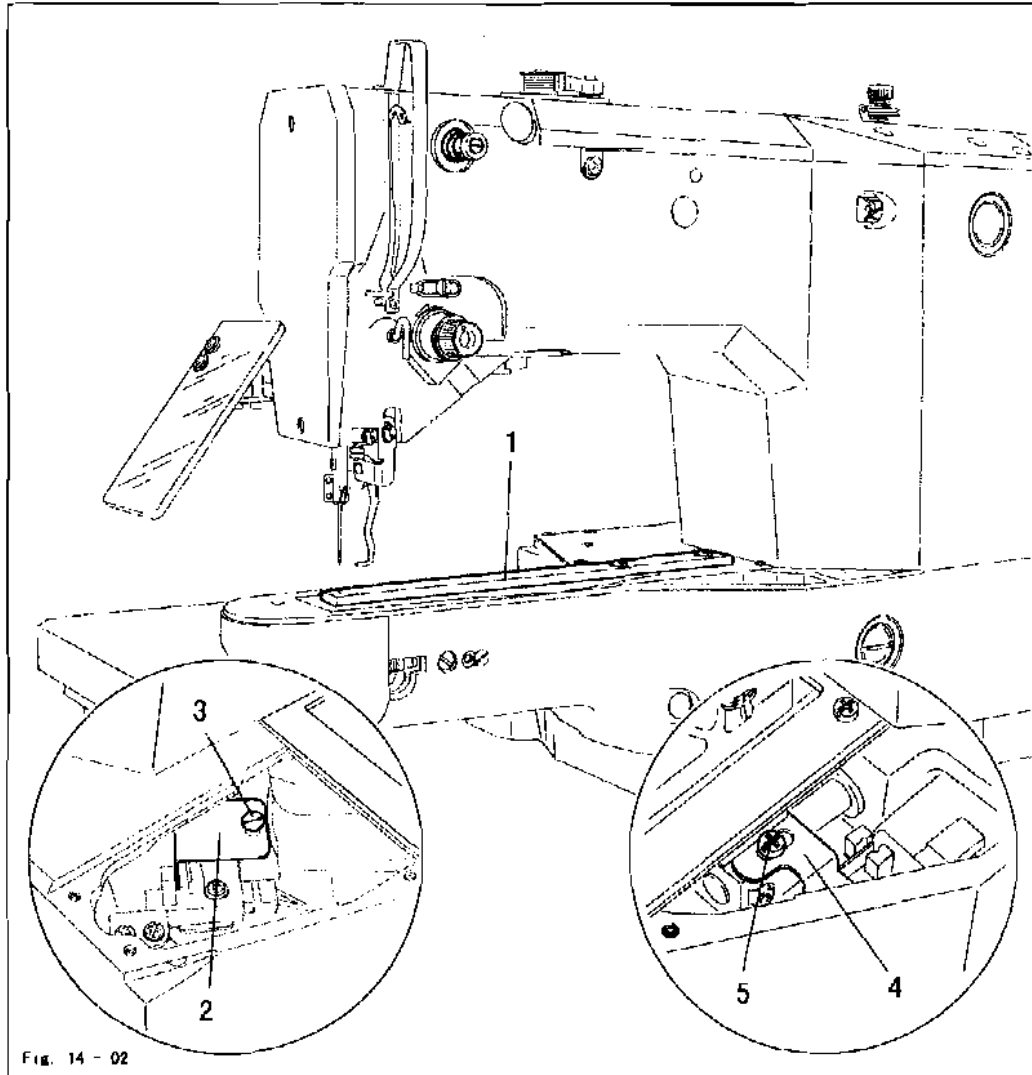

Fig. 14 - 02



When removing the work clamp holder, take care that the ball bearings in the arm support do not drop out !



- Remove the work clamp holder and the lower feed plate .
- Screw adjustment gauge 1 to the work clamp drive unit

Preliminary adjustment

- Move the work clamp drive unit by hand in accordance with requirement 1.
- Adjust switch lug 2 (screw 3) and switch lug 4 (screw 5) in accordance with requirement 2.

Fine adjustment

- Switch on the machine.
- In the input mode, input in the instruction manual.



- With the corresponding plus/minus key move the work clamp drive unit in accordance with requirement 1. input
- Switch off the machine.
- Remove adjustment gauge 1.
- Fit the lower feed plate and work clamp holder.



If, during the fina adjustment, the setting is 5 increments above or below the value in X- and Y-direction, the setting should be checked again in accordance with requirement 2.

Adjustment

14.07 Aligning the work clamp

Requirement

The work clamp should be aligned in "X" and "Y" direction, so that it does not touch the needle during sewing.

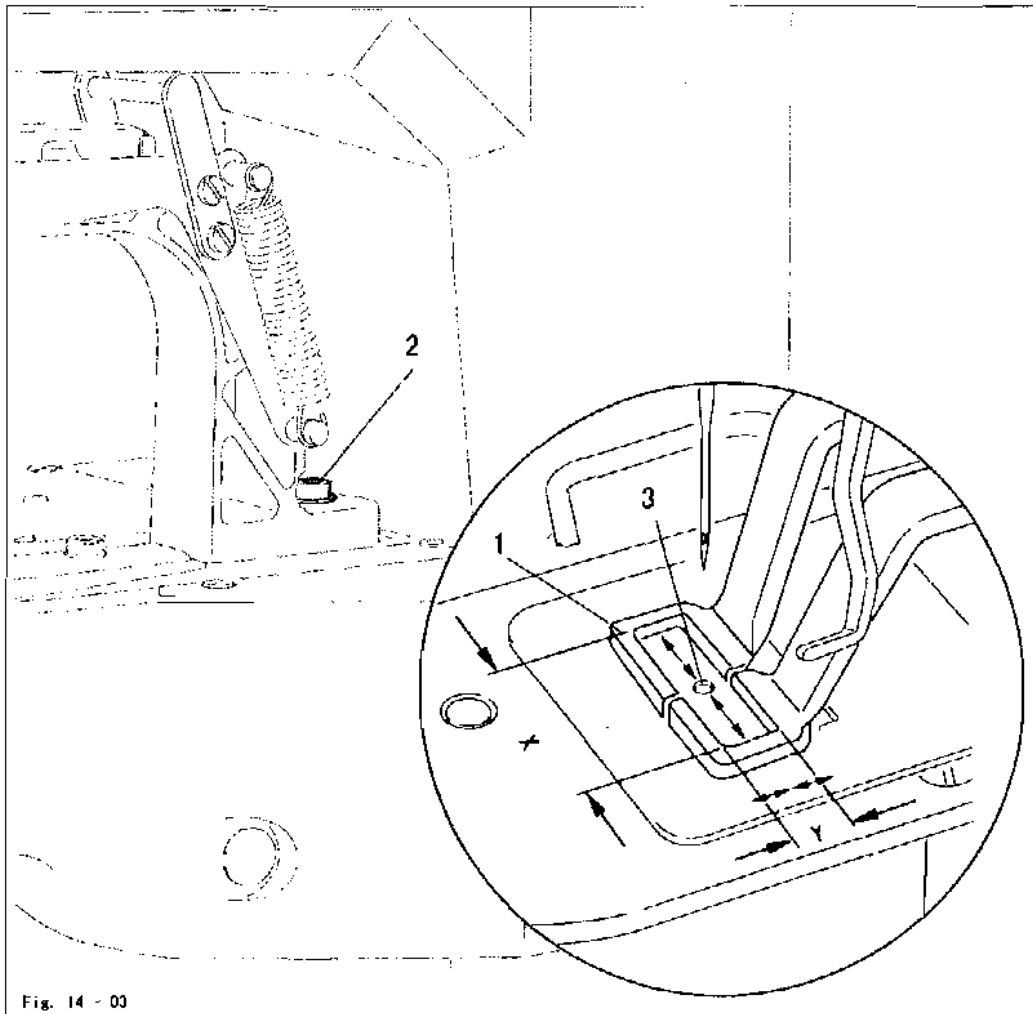

Fig. 14 - 03



- Switch on the machine
- Set the sewing area size
- In the input mode, input in the instruction manual
- Align work clamp (screw 2) so that the needle hole 3 is in the centre of the work clamp outlet.



Checking the "Y-direction"

- To check this adjustment, move along the maximum set sewing area size in "Y-direction" by pressing the corresponding plus/minus keys (readjust if necessary).



Checking the "X-direction"

- Move along the maximum set sewing area size in "X-direction" by pressing the corresponding plus/minus keys.

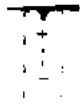

- If necessary adjust the position of work clamp by entering a correction value "X" with the corresponding plus/minus keys in "X-direction" in accordance with the requirement.



- Conclude the input.



When using the max sewing area size (X=40mm, X=20 mm), the correction value must be set at "0".

Adjustment

14.08 Hook driver

Requirement

1. When the balance wheel is turned, the machine should not bind.
2. The play of catch 7 should be less than 0.1 mm.

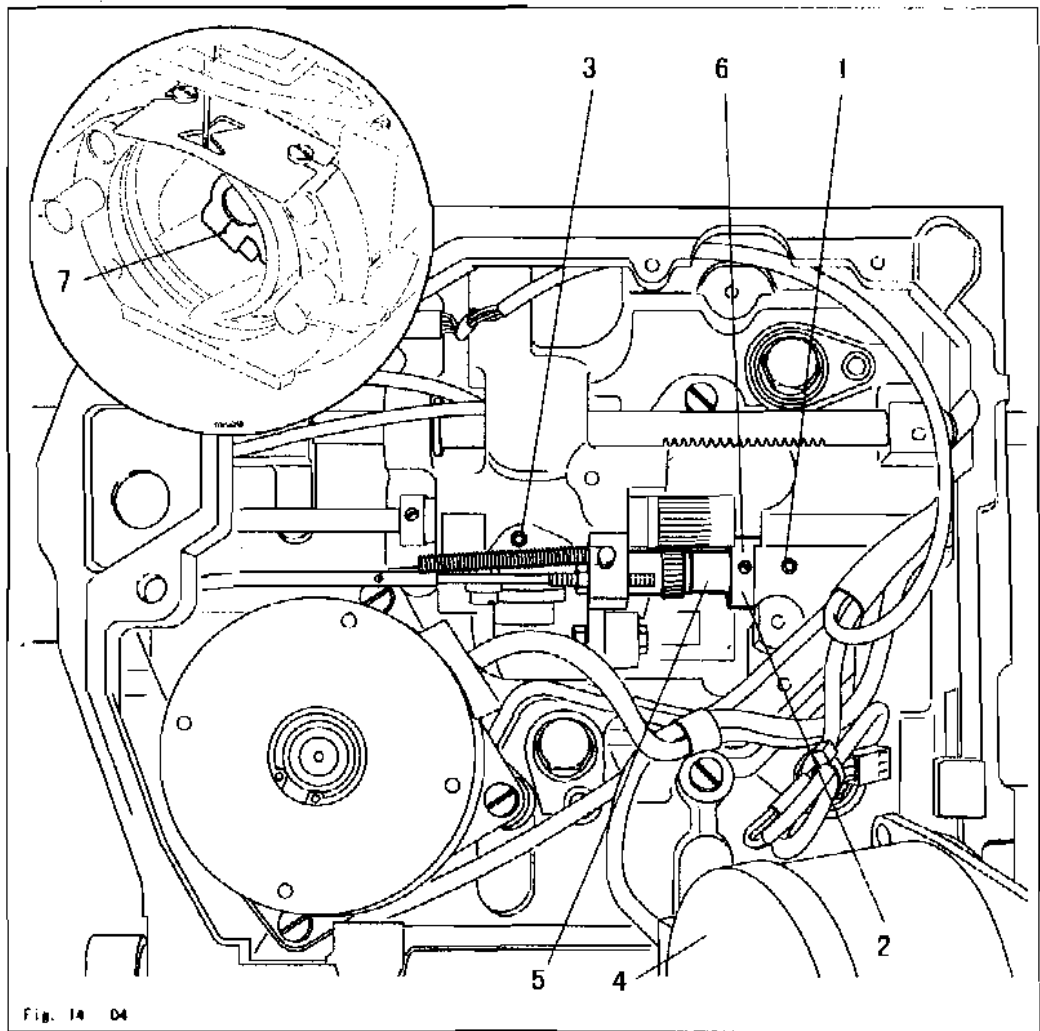

- Remove the hook
- Loosen screws 1, 2 and 3 (remove motor 4).
- Move the eccentric shaft 5 in accordance with requirement 1 and twist it in with accordance requirement 2.
- Tighten screws 1 and 3.
- Move adjustment ring 6 against the metal edge and tighten screw 2.
- Insert the hook.

If catch 7 has too much play, the running noise of the machine increases. Too little play may cause the machine to jam.

14.09 Needle height

Requirement

With the needle bar in b. d. c., depending on the sub-class the marking on needle bar 1 described below should be flush with the lower edge of the needle bar bush:

Sub-class -02 top marking.

Sub-class -01 second marking from the bottom.

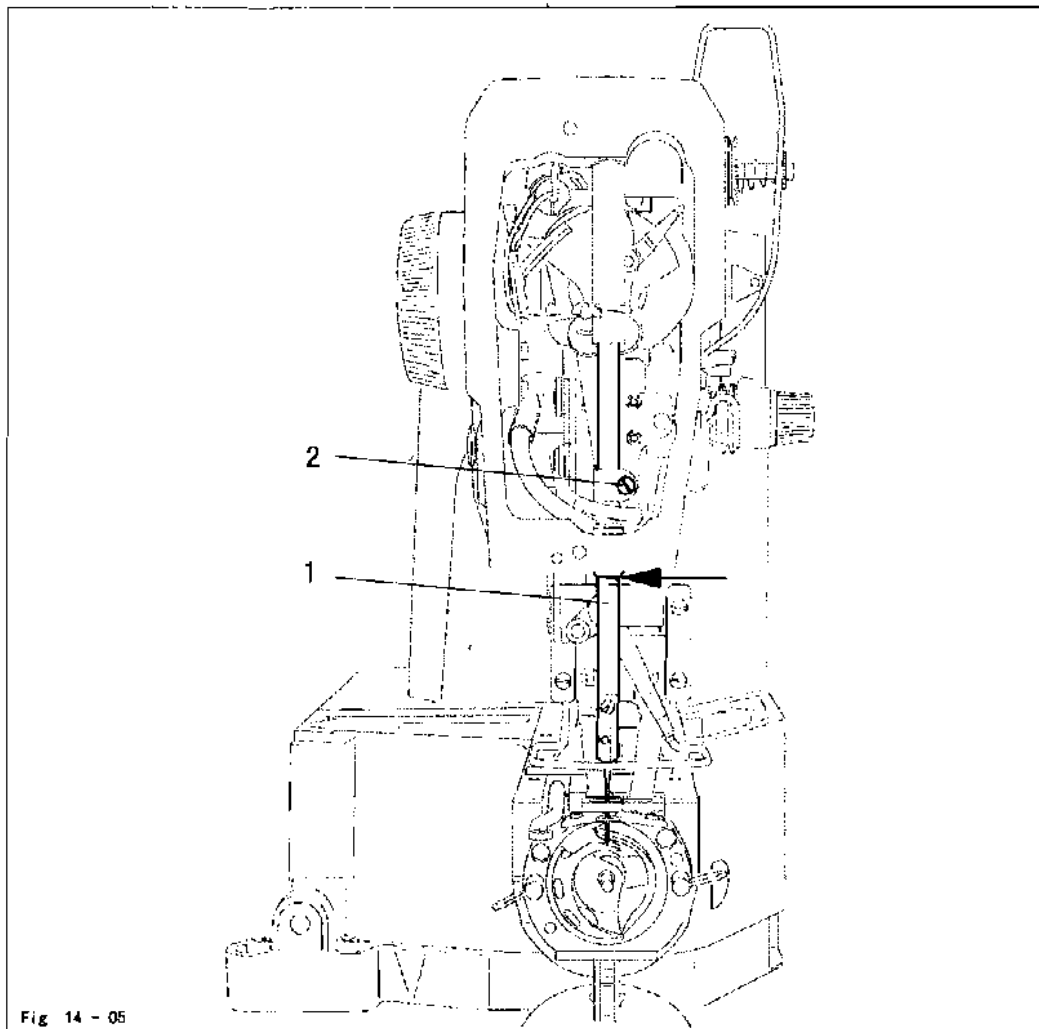

Fig 14 - 05



- Adjust needle bar 1 (screw 2) in accordance with the requirement.

Adjustment

14.10 Hook-to-needle clearance

Requirement

When the bottom marking of the ascending needle bar is level with the lower edge of the needle bar bush

1. hook 5 should be 0.05 - 0.10 mm behind the needle and
2. the distance between the needle and the tip of the hook race should be 7.5 mm.

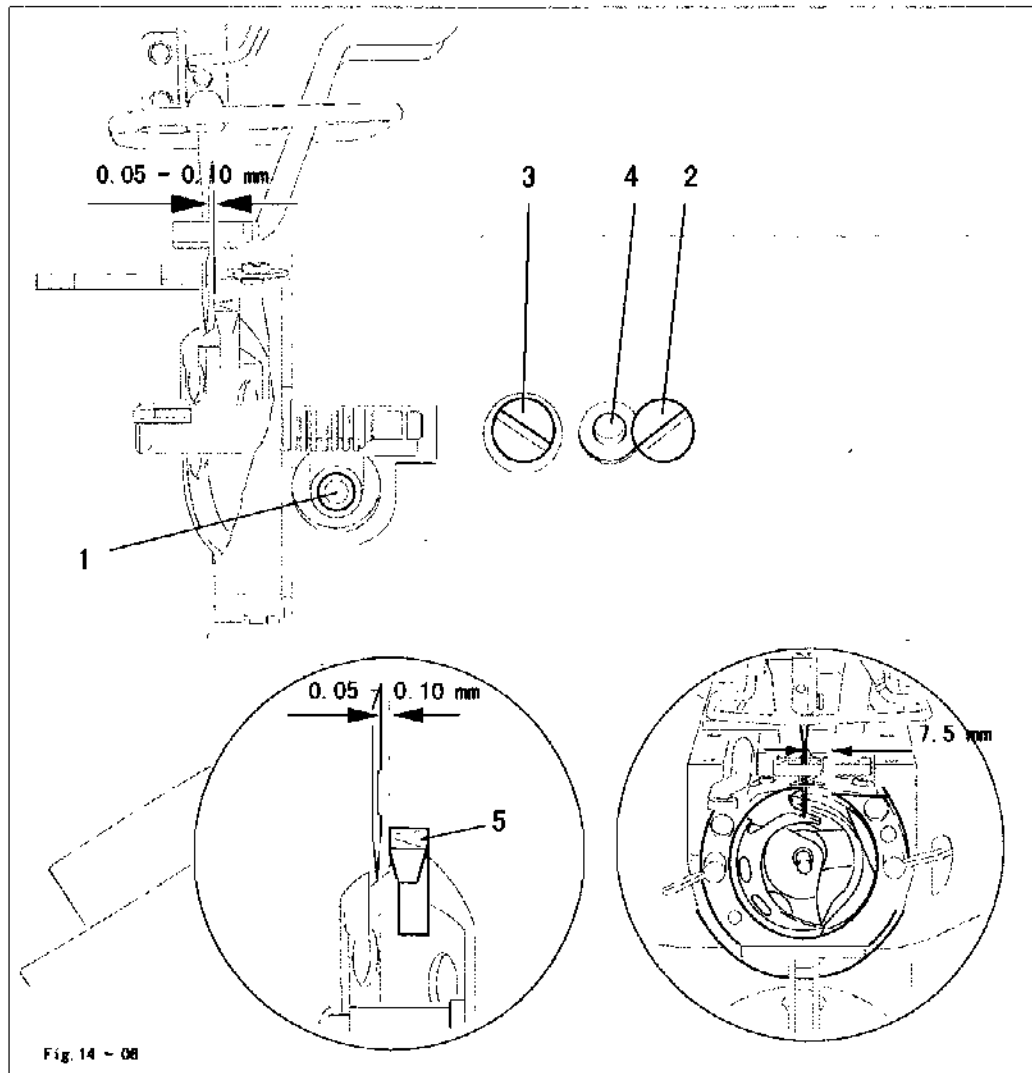

- Loosen screws 1, 2 and 3.
- Turn the eccentric pin 4 in accordance with the requirements.
- Tighten screws 2 and 3.



Screw 1 remains loosened for further adjustments.

Adjustment

14.12 Aligning the hook race cover

Requirement

The needle should be centred to cutout B and the rear side of the needle flush to the imaginary line A.

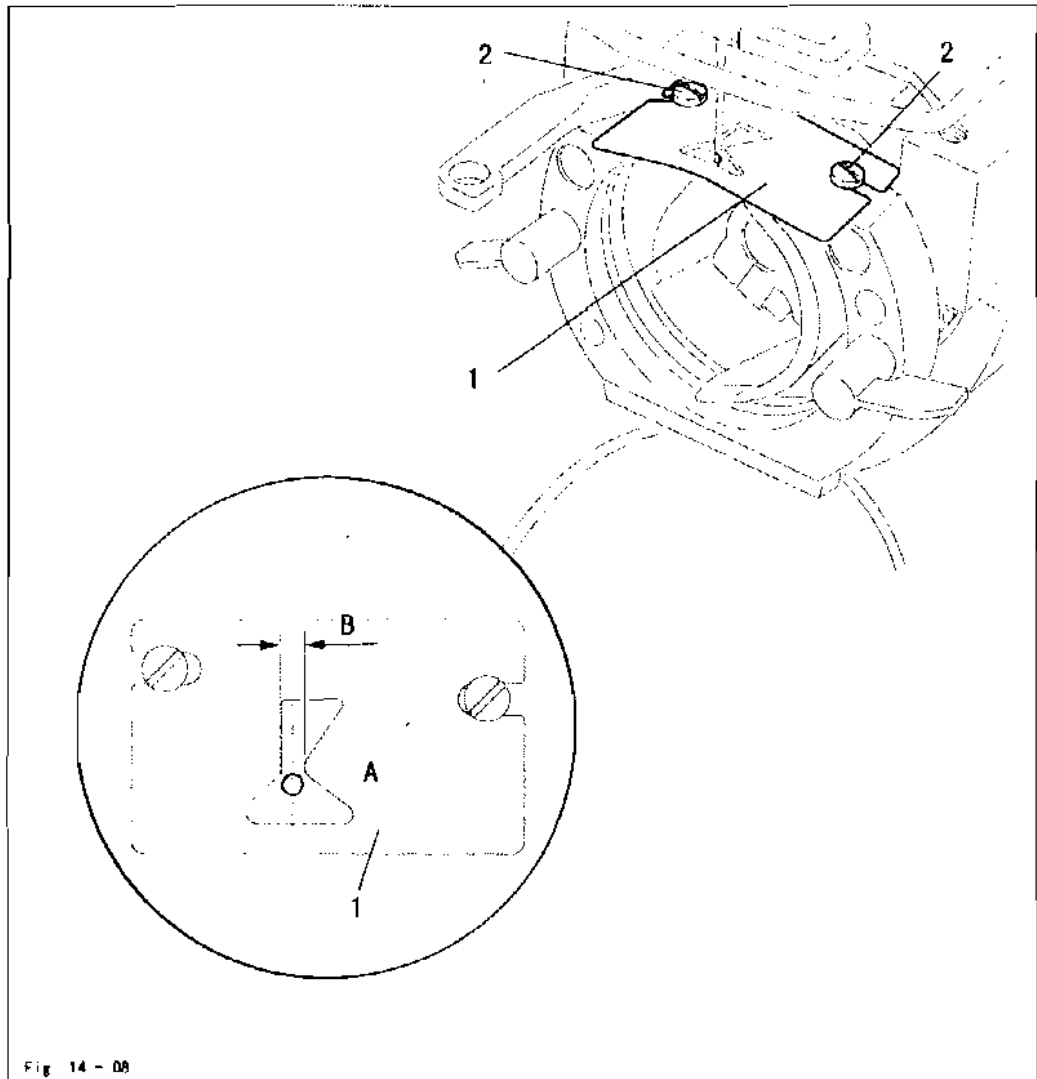

- Move the hook race cover 1 (screws 2) in accordance with the requirement.

14.13 Work clamp height

Requirement

1. The work clamp should be 3 mm above the upper edge of the needle plate.
2. Both halves of the work clamp should be parallel to each other.

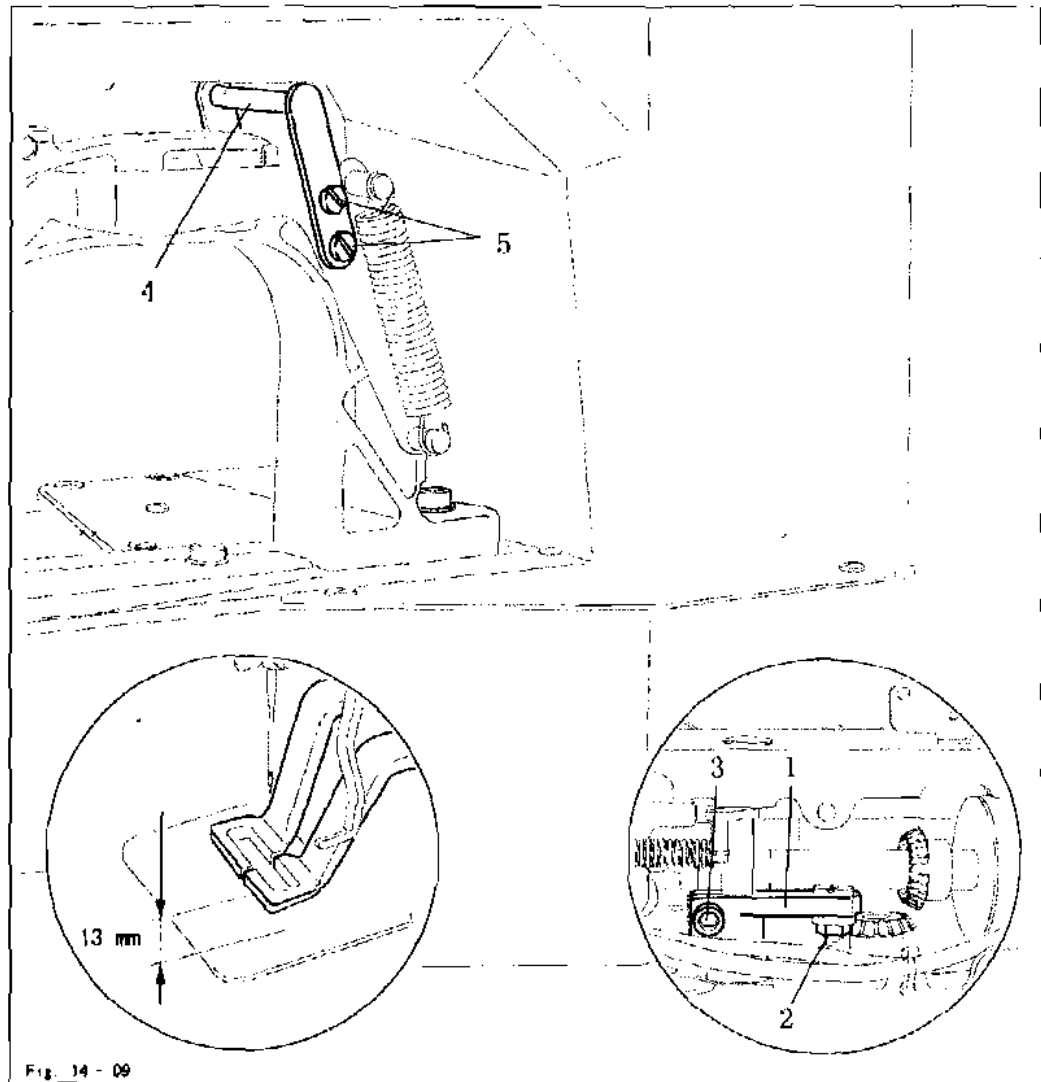

- Turn lever 1 (nut 2 and screw 3) in accordance with requirement 1.
- Move lift plate 4 (screws 5) in accordance with requirement 2.



After aligning the work clamp, it is imperative to check the position of the thread wiper, see Chapter 14.14. Position of the thread wiper!
Danger of needle breakage!

Adjustment

14.14 Position of the thread wiper

Requirement

When the thread wiper is centred to the needle, its lower edge should be 14 - 15mm above the upper edge of the needle plate.

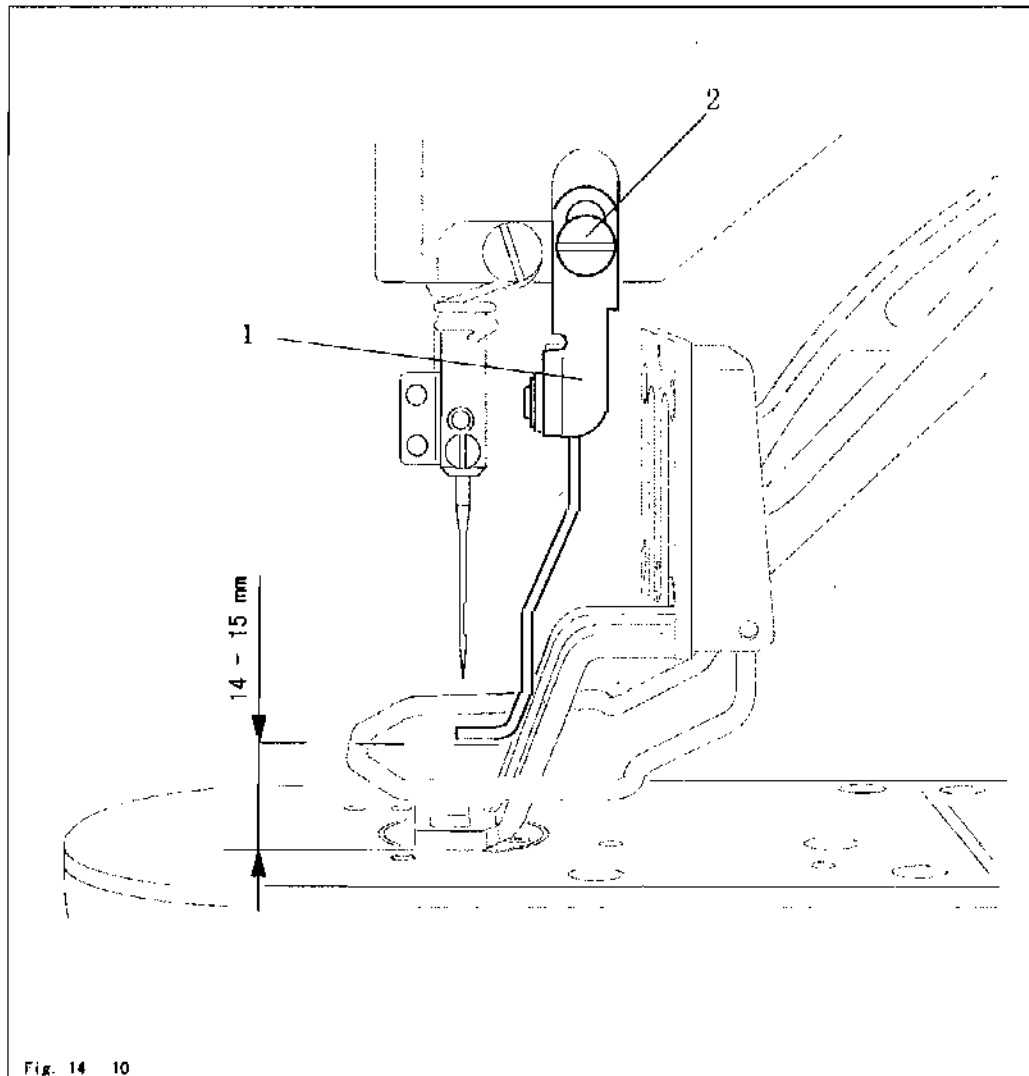

- Bring the thread wiper 1 into the appropriate position by operating the work clamp manually.
- Move thread wiper 1 (screw 2) in accordance with the requirement.

14.15 Position of the control cam

Requirement

1. The markings on control cam and arm shaft should correspond with each other.
2. The outer edge of control cam should be at a distance of 32.5 mm from the metal surface of the case.

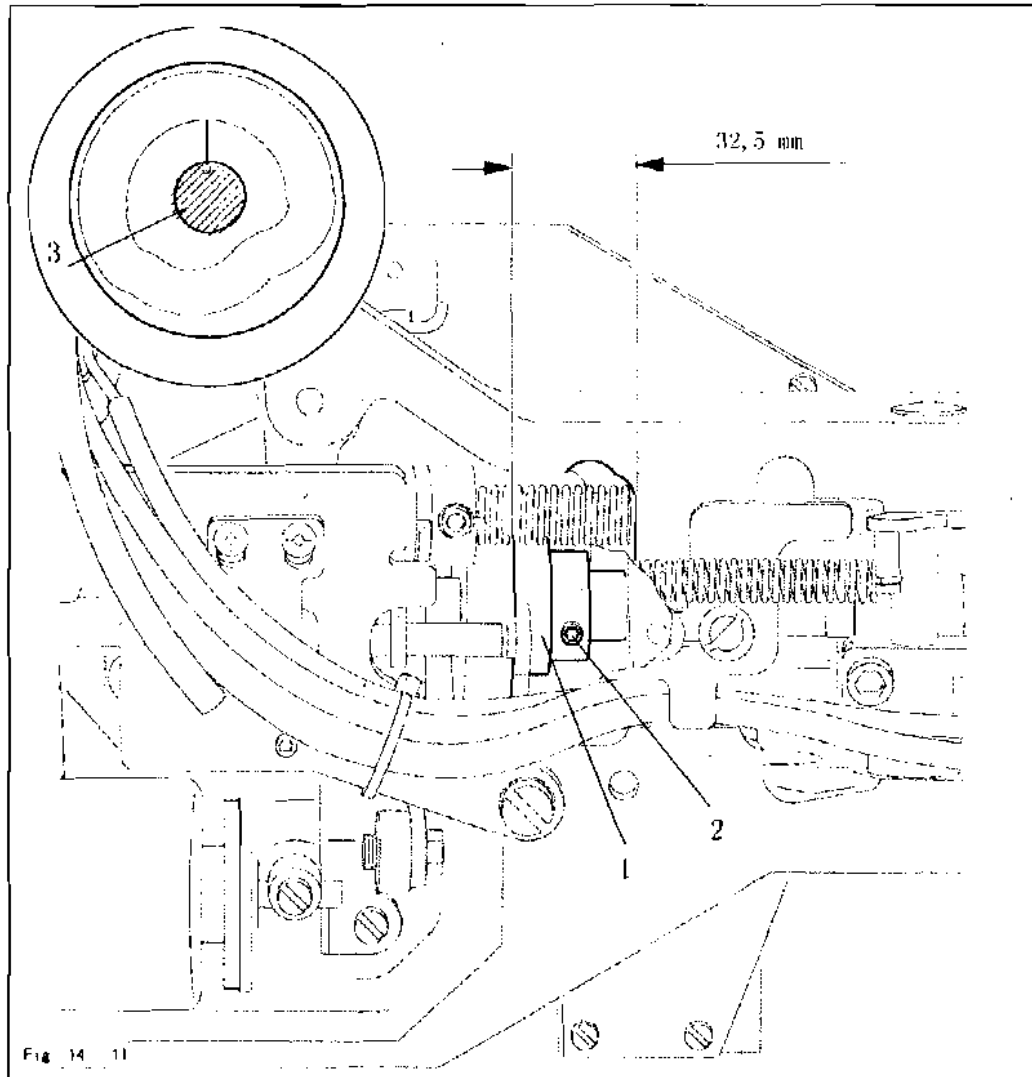

Fig. 14. 11



- Turn control cam (1) (screw 2) in accordance with requirement 1, or move it in accordance with requirement 2.

Adjustment

14.16 Position of the control roller

Requirement

When the needle bar is at its b.d.e., the control roller should be centred to the running path of control cam 2.

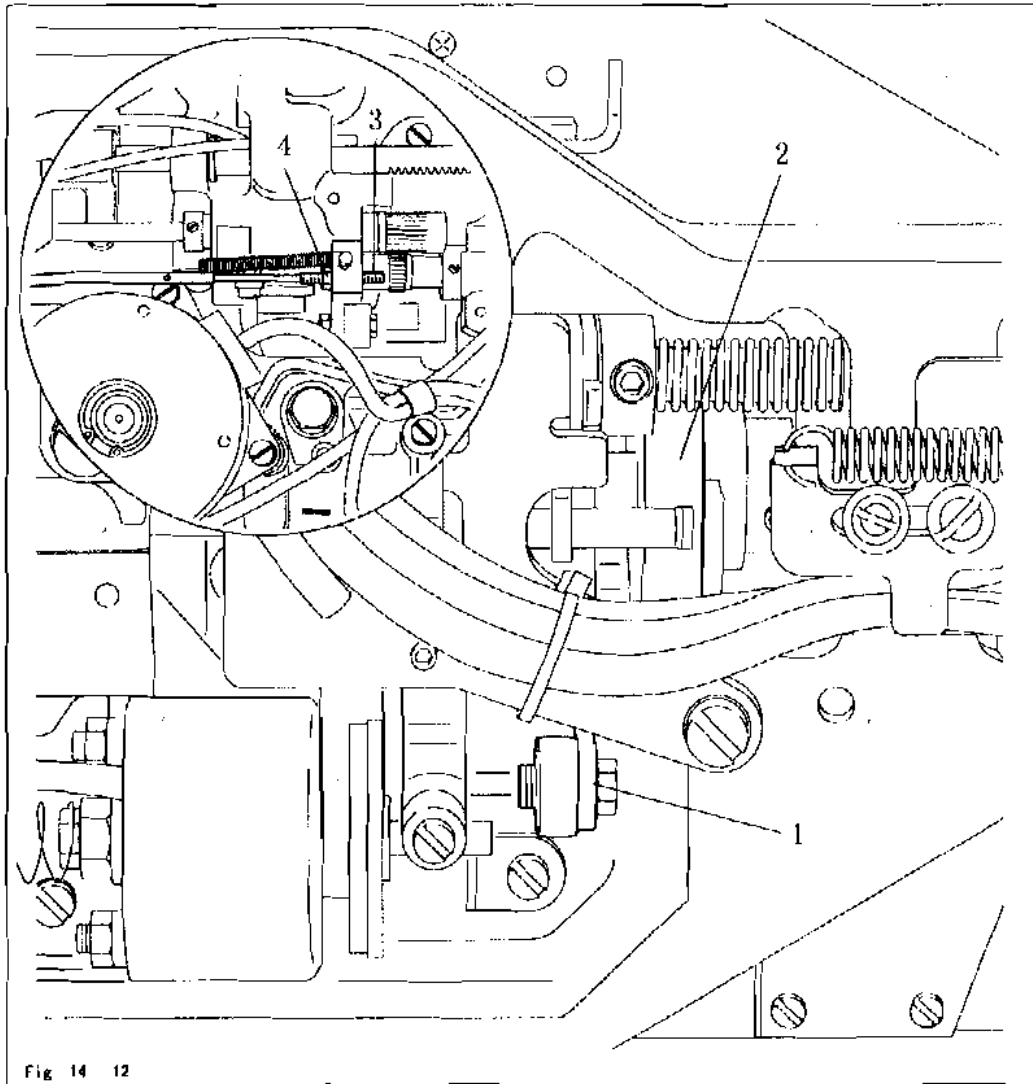

- Turn screw 3 (nut 4) in accordance with the requirement.
- For checking purposes, operate lever 1 by hand to let the control roller fall into the running path of control cam 2.

14.17 Position of the drive shaft of the thread trimmer

Requirement

When the thread trimmer is in its basic position, shaft 1 should be flush with the metal edge of the machine case.

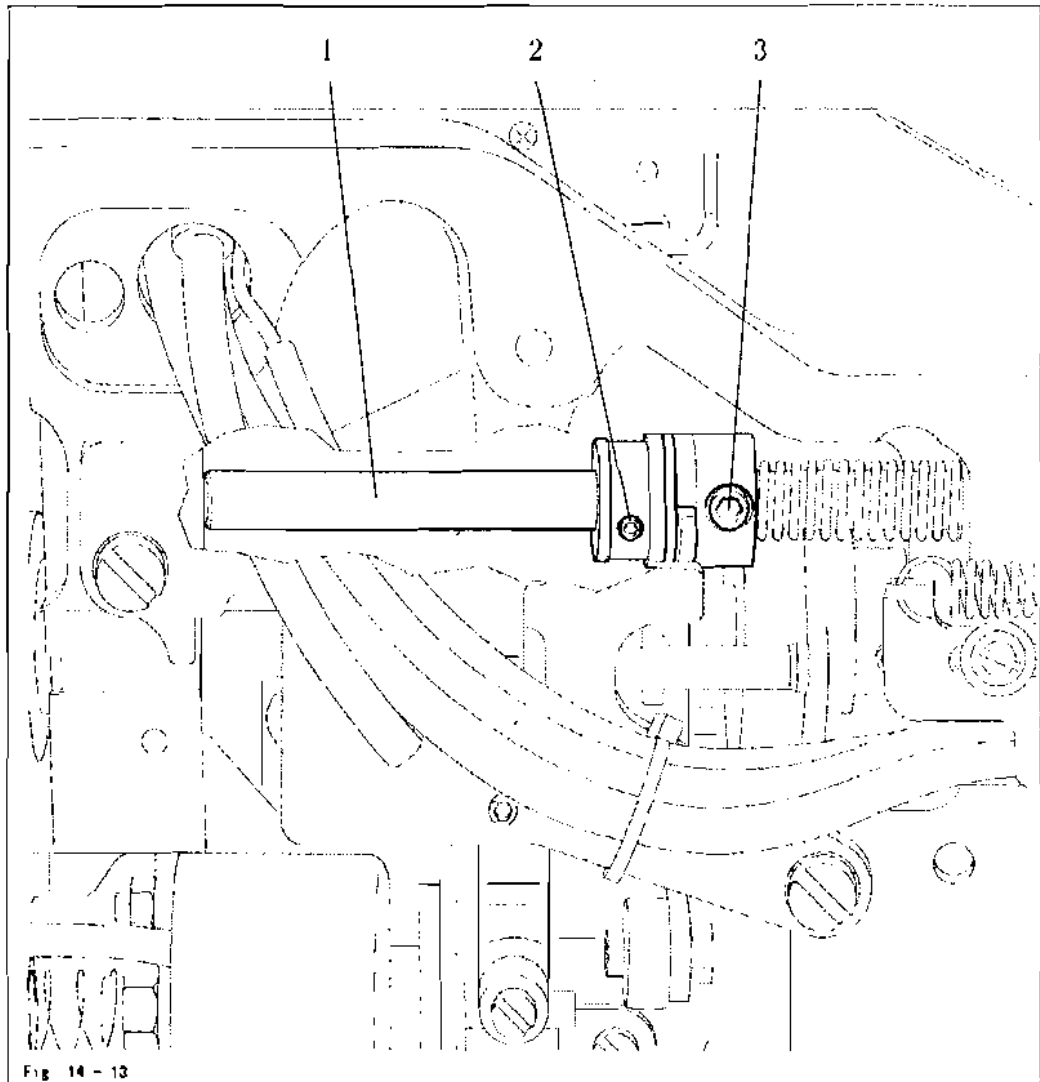

- Move shaft 1 (screws 2 and 3) in accordance with the requirement.

Adjustment

14 18 Aligning the stop plate

Requirement

When the thread trimmer is in its basic position, there should be a clearance of 0.3 mm between lever 3 and plate 1.

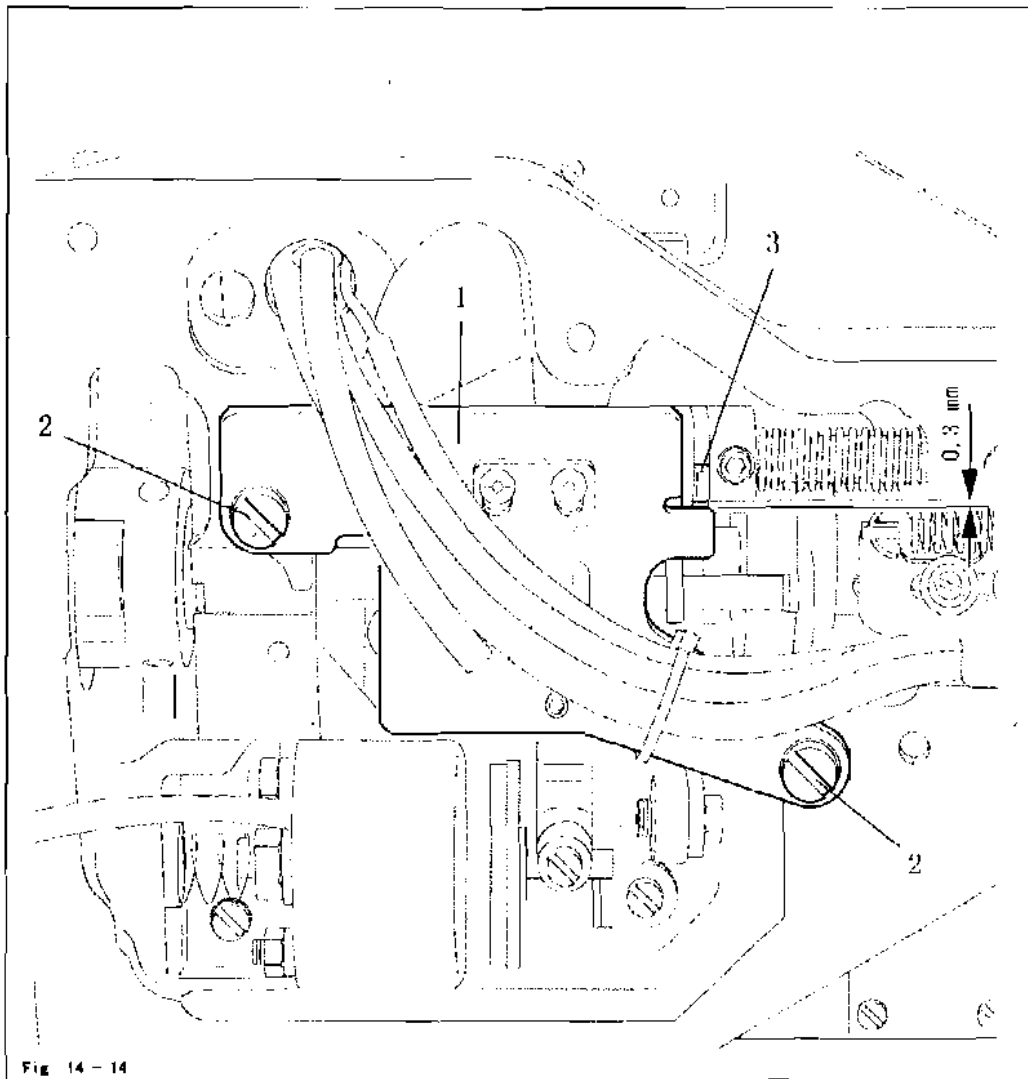

FIG 14 - 14



- Move plate 1 (screws 2) in accordance with the requirement.

14.19 Adjusting the trimmer solenoid

Requirement

When the thread trimmer is in its neutral position, solenoid 1 should be at a distance of 5 mm from the case.

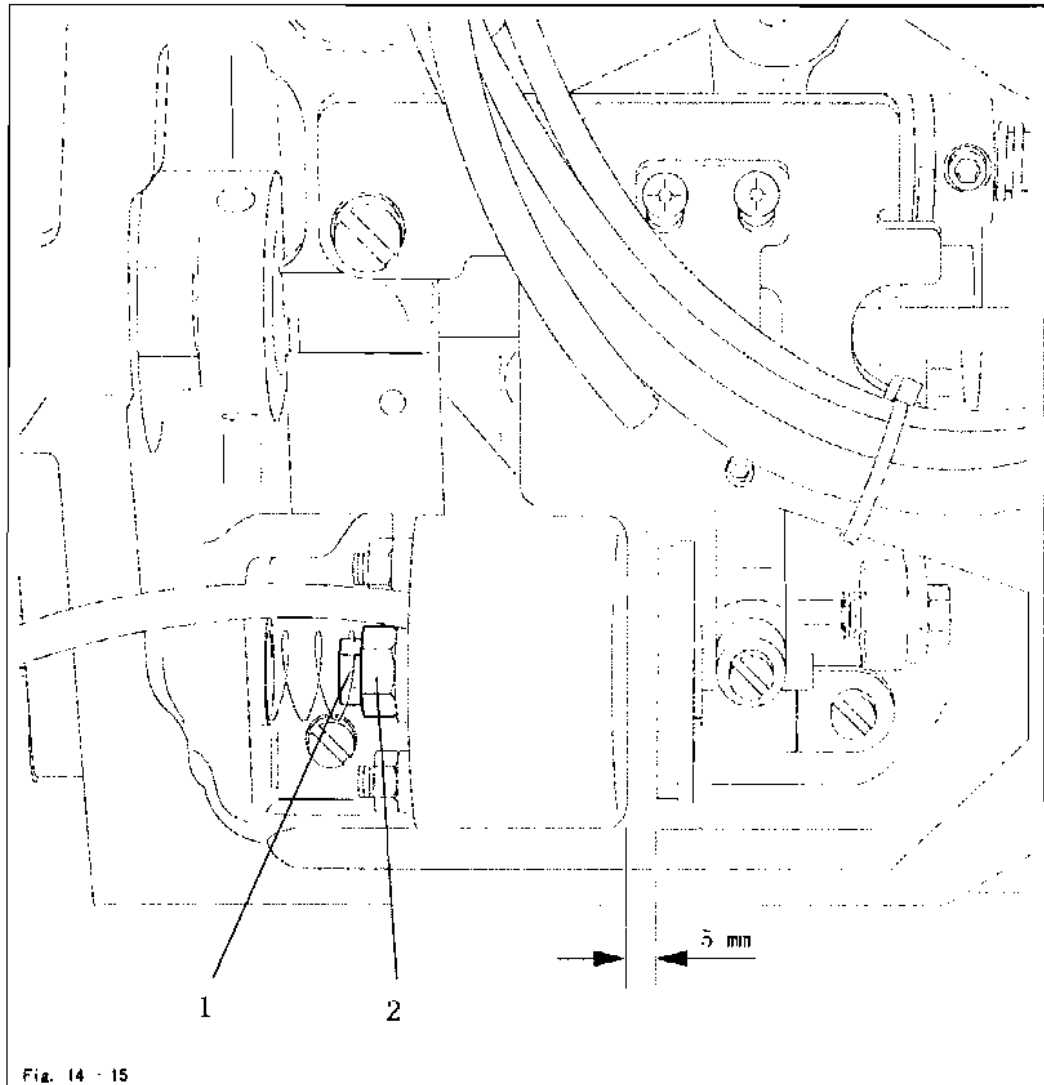

- Turn nut 1 (nut 2) in accordance with the requirement.

Adjustment

14 20

Adjusting the engaging lever

Requirement

When the thread trimmer is in its neutral position, pin 3 should be at a distance of 0.5 mm from release trip 4.

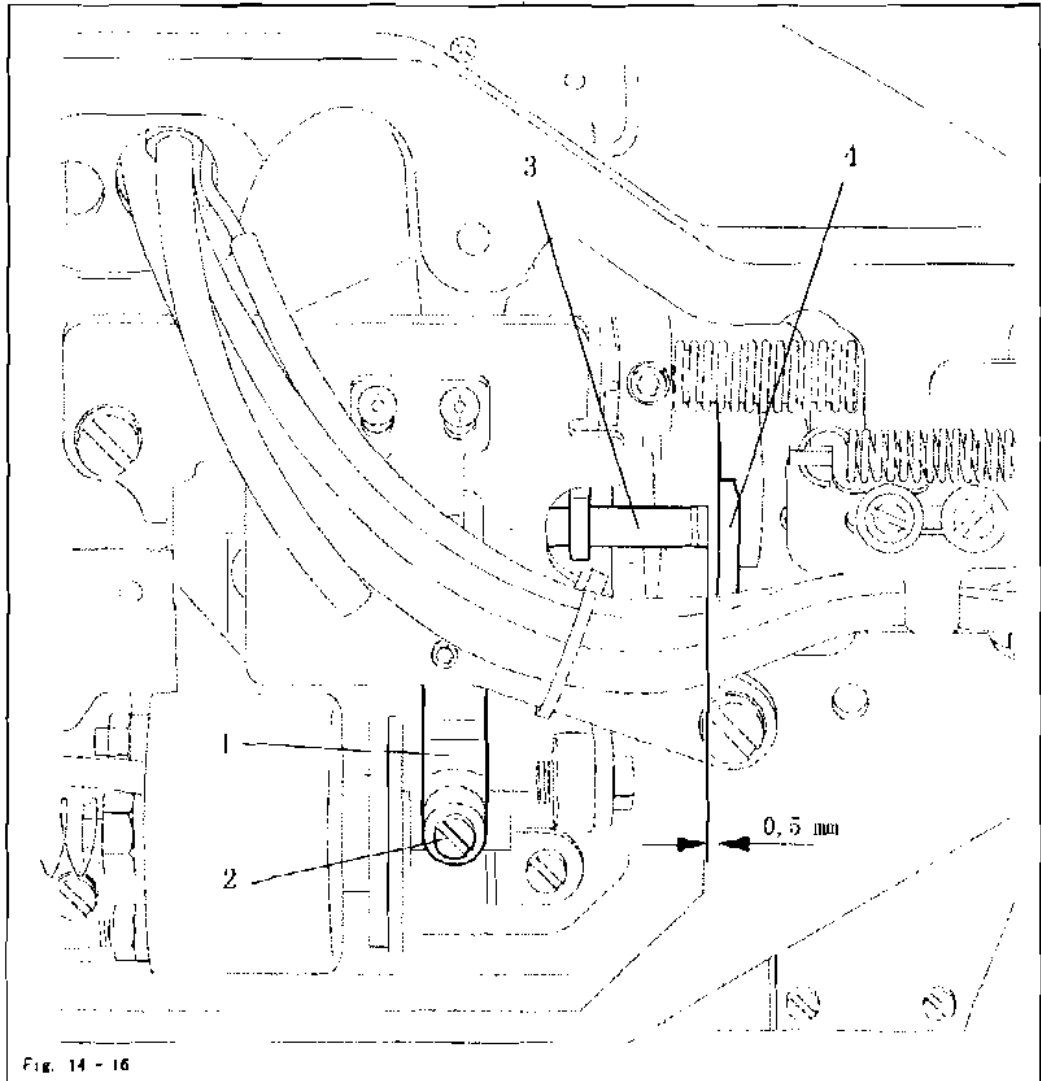

- Move lever 1 (screws 2) in accordance with the requirement.

14.21 Position of the thread catcher and knife

Requirement

When the machine is in its basic position

1. The blade of knife 2 should be at distance of 0.5 mm from the needle plate insert.
2. The tip of the thread catcher 4 should be at a distance of 3.5 mm from the blade of knife 2.

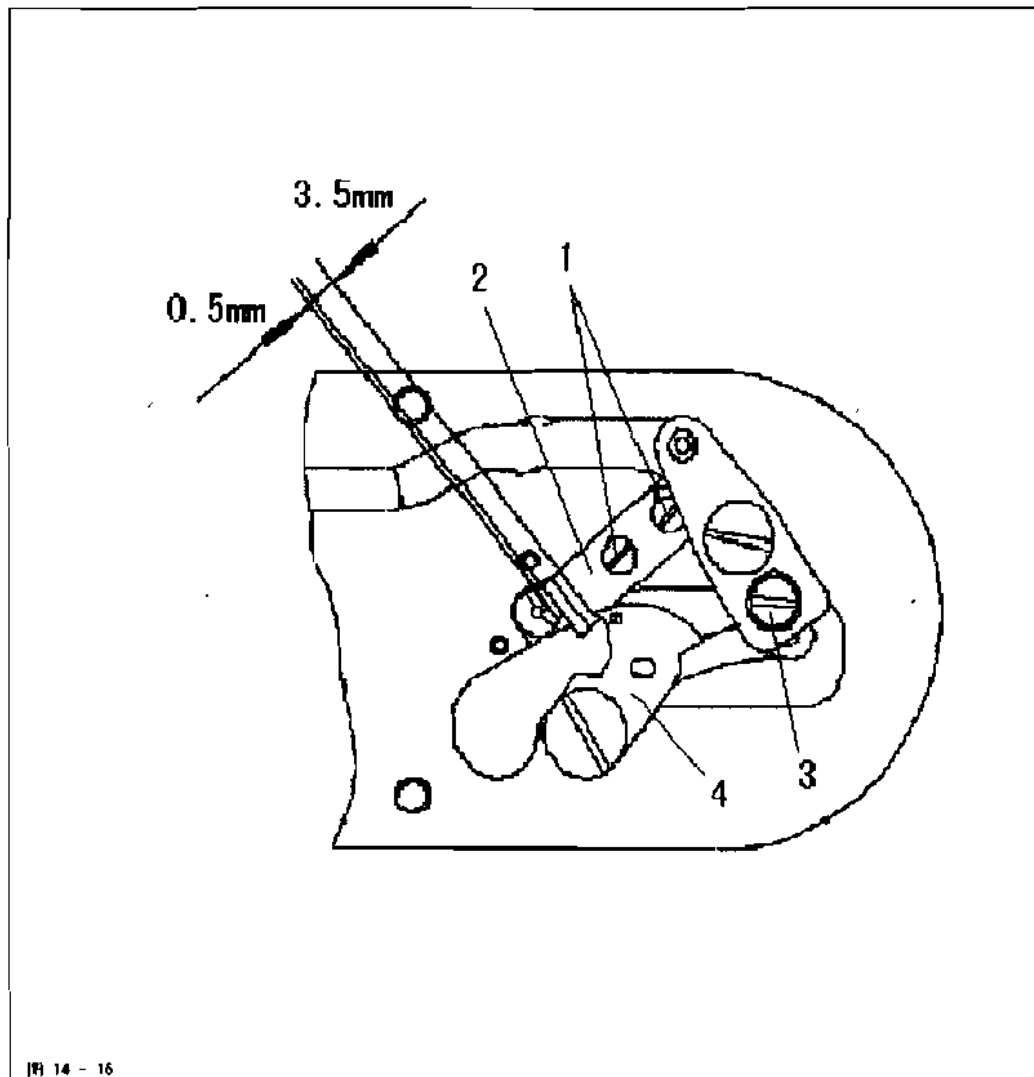

- Adjust knife 2 (screw 1) in accordance with requirement 1.
- Adjust thread catcher 4 (screw 3) in accordance with requirement 2.

Adjustment

14.22 Position of the release trip

Requirement

The slots of trip 1 should be touching screws 2 on the right side.

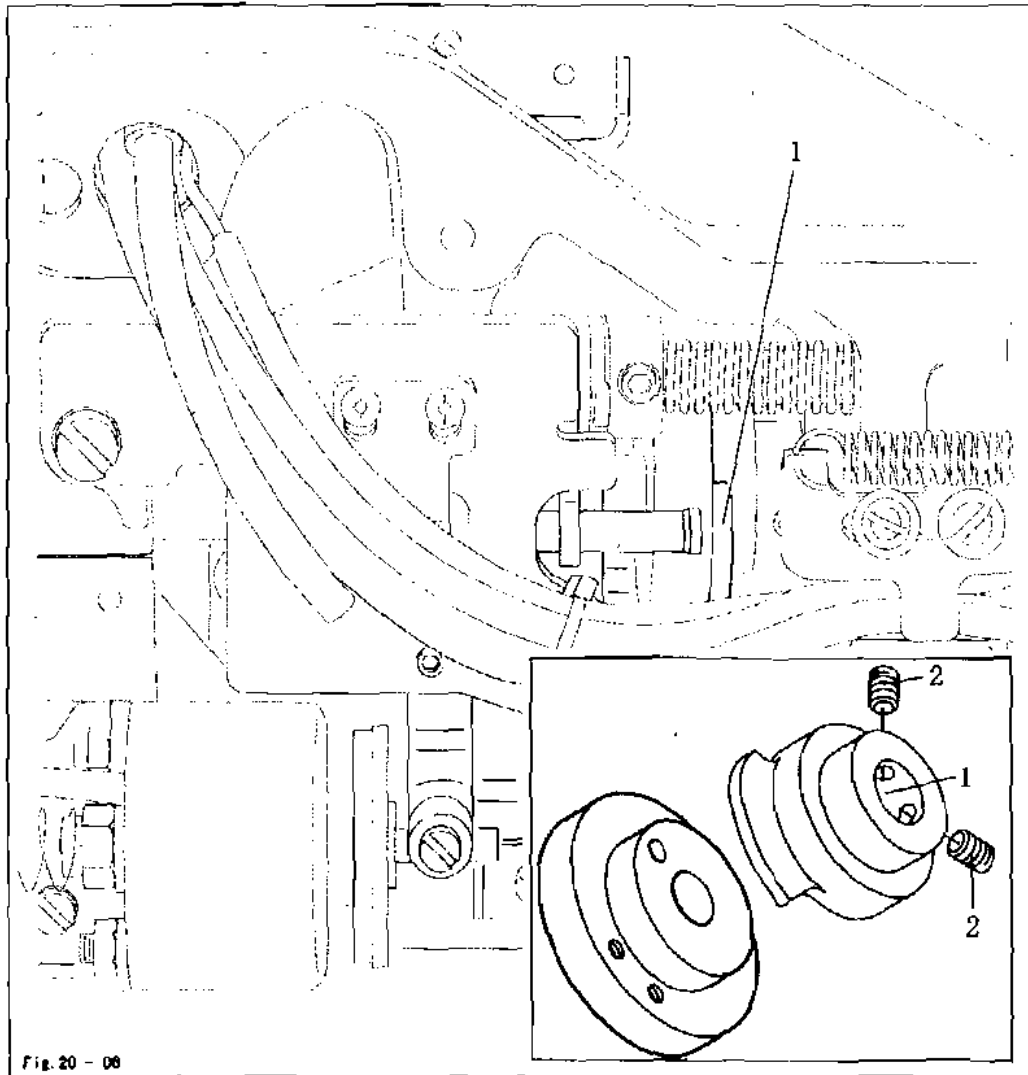

Fig. 20 - 00



- Move trip 1 (screws 2) in accordance with the requirement.



If the needle thread is too short after trimming, trip 1 can be slightly readjusted.

14.23 Position of the release catch

Requirement

When lever 6 is touching release catch 7, there should be a distance of 0.3 mm between drive lever 5 and pin 1.

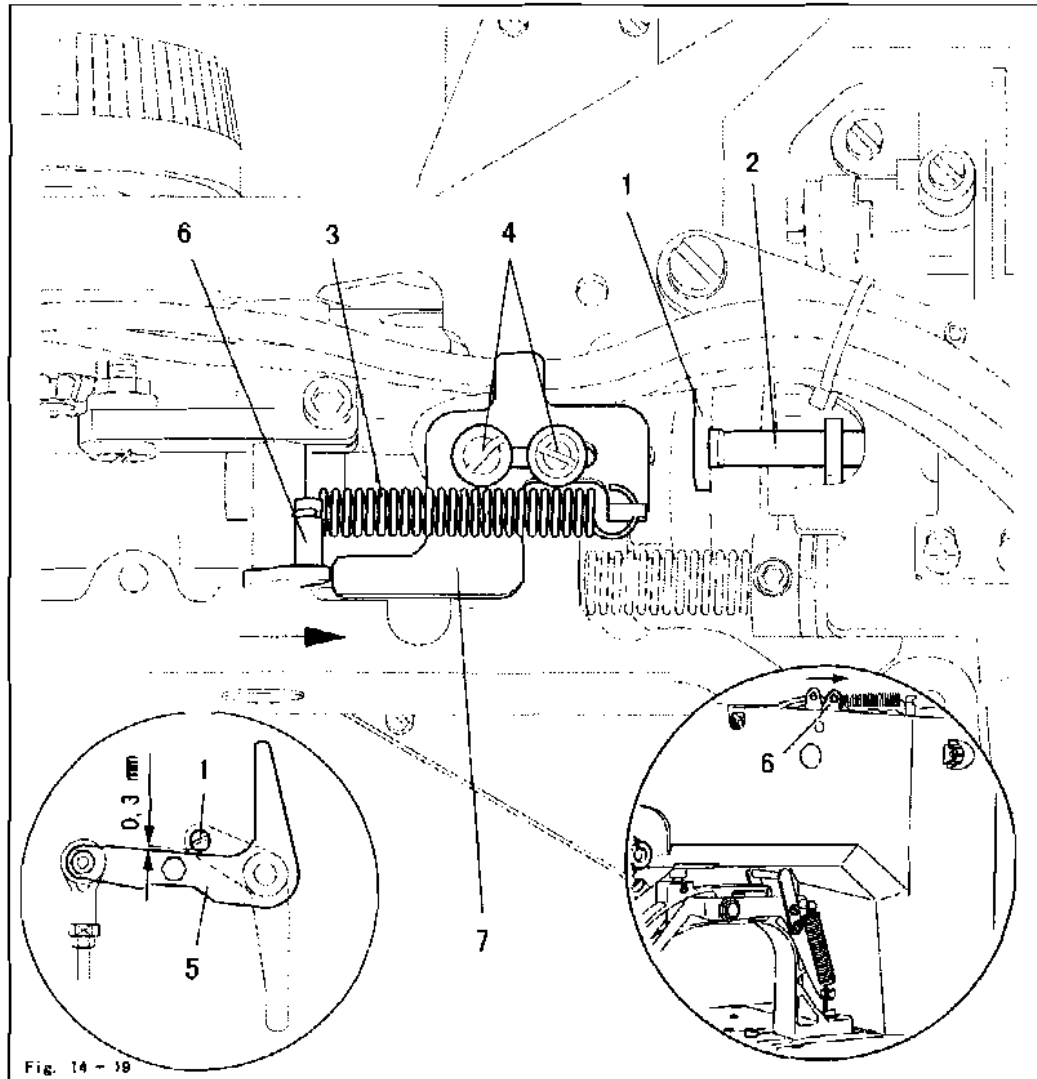

Fig. 14 - 18



- Turn the balance wheel until pin 1 is no longer on the release trip 2.
- Release spring 3 and loosen screws 4.
- In accordance with the requirement, place the feeler gauge between the drive lever 5 and pin 1.
- Push lever 6 lightly in the direction shown by the arrow.
- Move release catch 7 against lever 6 and tighten screws 4.
- Remove the feeler gauge and attach spring 3.



Spring 3 should only be released and attached with suitable tools!
Danger of injury!

Adjustment

14.24 Needle thread tension release

Requirement

After thread trimming the distance X between tension discs 3 should be 0.6 - 0.8 mm for normal materials and 0.8 - 1.0 mm for heavy materials.

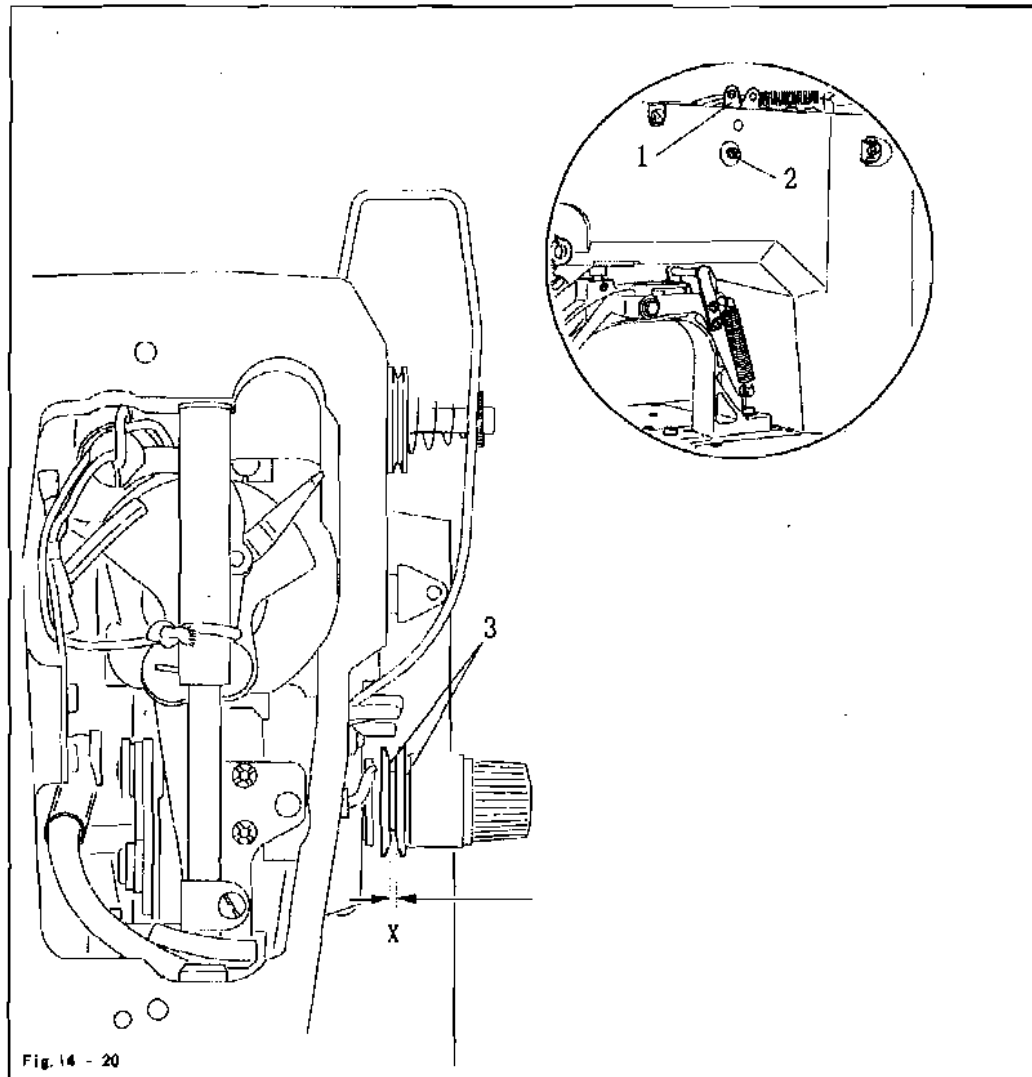

- Bring the machine into the cutting position by hand.
- Move lever 1 (screw 2) in accordance with the requirement.

14.25 Thread check spring and thread regulator

Requirement

1. The thread check spring 1 should have a 6 - 8 mm stroke.
2. Screw 4 should be positioned in the centre of the slot of thread regulator 3.

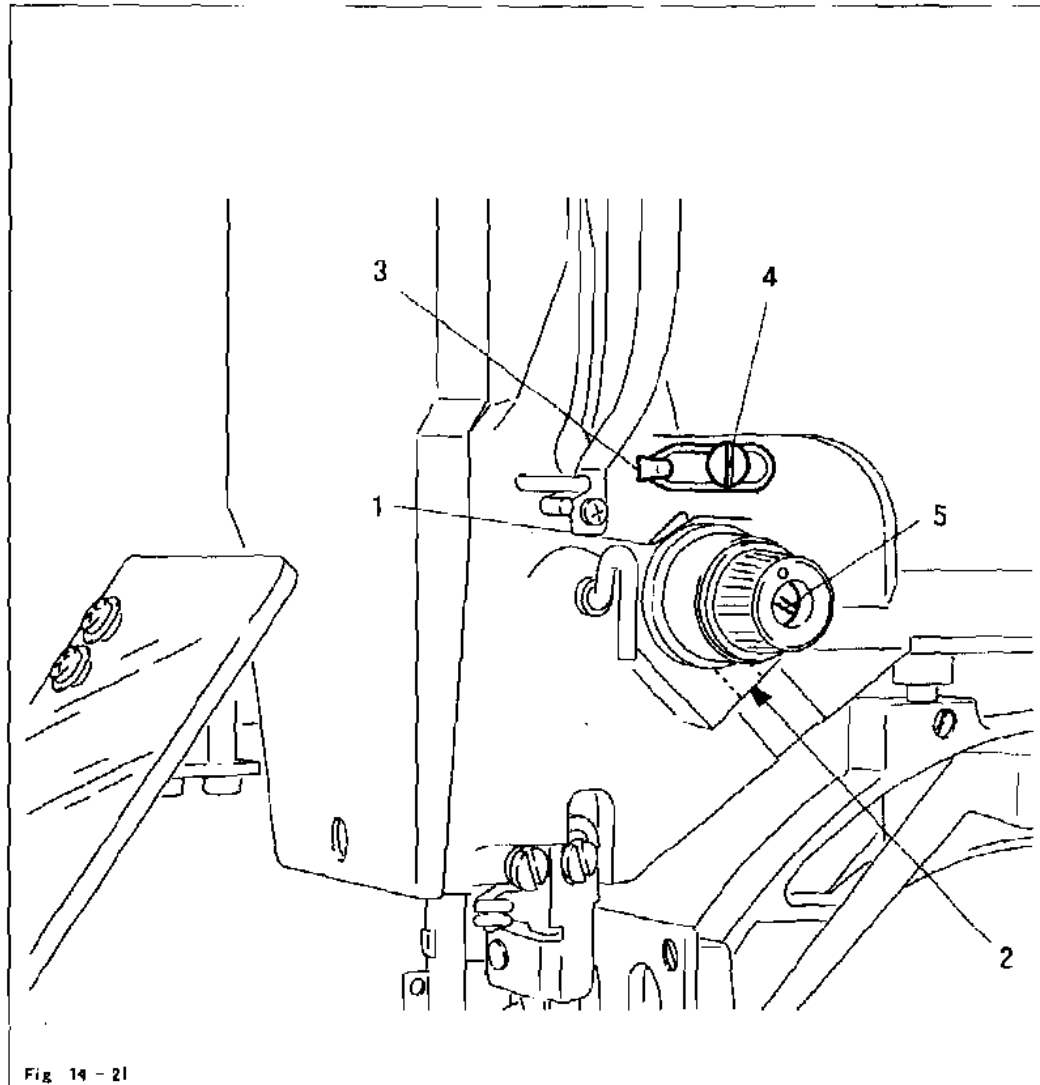

- Adjust thread check spring 1 (screw 2) in accordance with requirement 1.
- Move thread regulator 3 (screw 4) in accordance with requirement 2.



Turn pin 5 to adjust the thread spring resistance. All settings of the thread check spring 1 depend on the material and might have to be corrected to achieve the desired result.

Adjustment

14.26 Bobbin winder drive wheel

Requirement

1. There should be a distance of approx. 10.5 mm between drive wheel 1 and the metal edge of the machine case.
2. When the bobbin winder is switched on, its friction wheel should be driven by drive wheel 1. When the bobbin winder is switched off, drive wheel 1 must not touch the friction wheel of the bobbin winder.

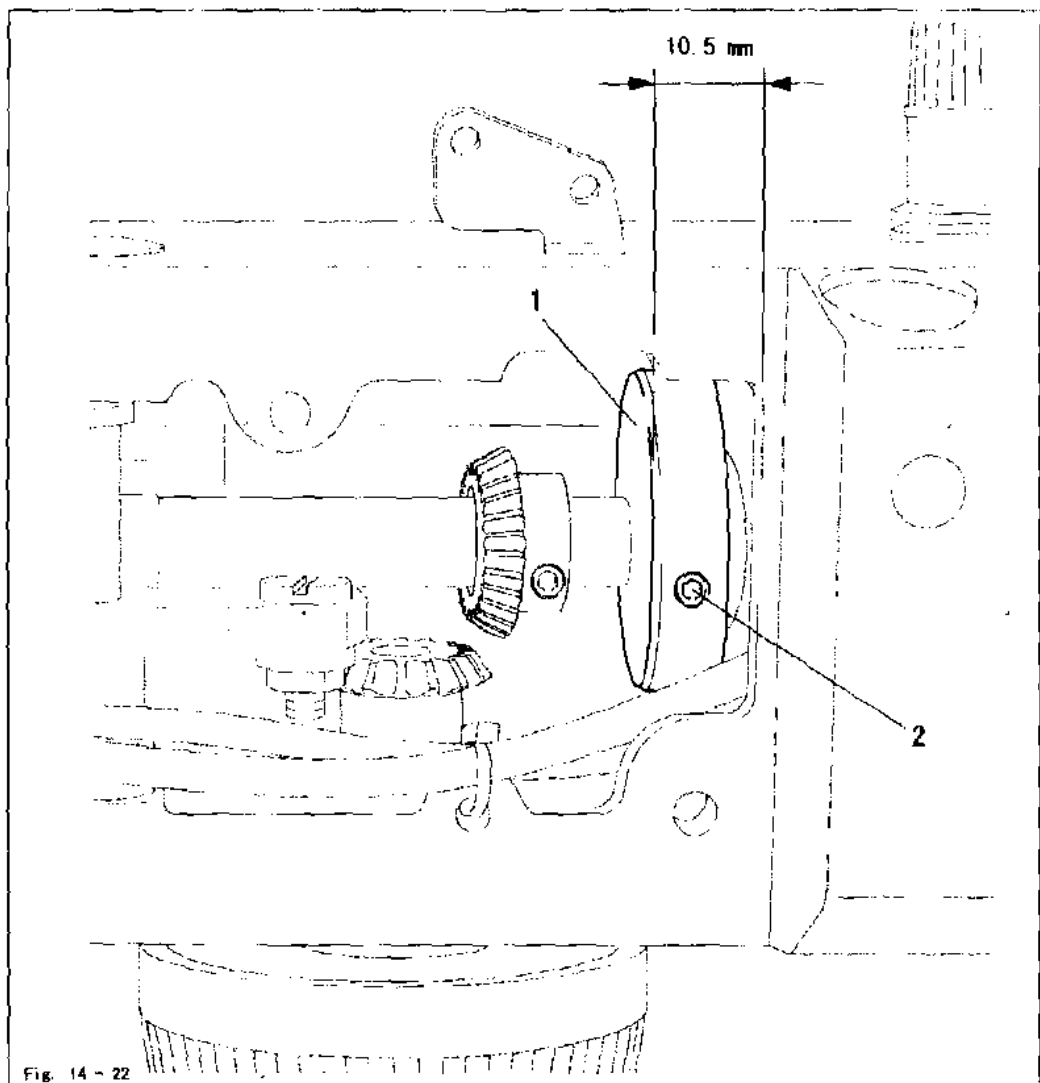

- Adjust drive wheel (screw 2) in accordance with the requirements.

14 27 Work clamp initiator

Requirement

When the work clamp is lowered and shortly before lever 5 in the machine arm touches stop 6, the initiator should switch on.

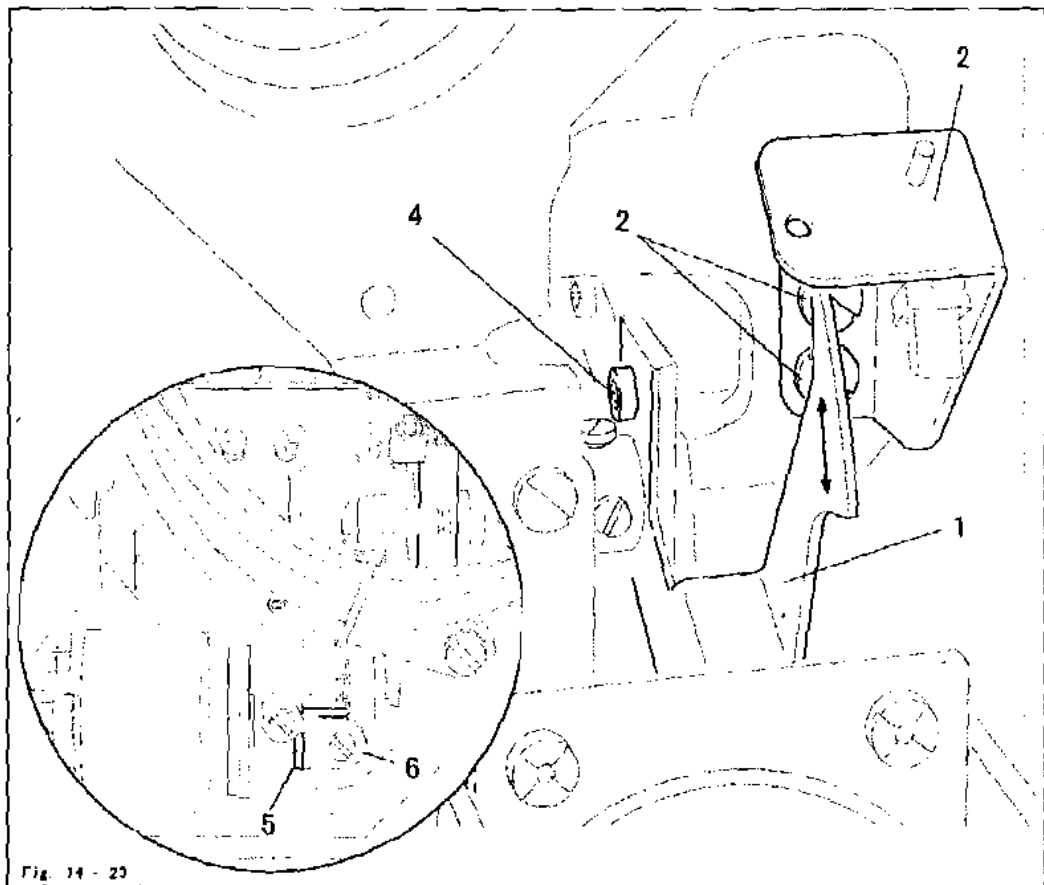

Fig. 14 - 23

Adjustment

14.28 Changing the work clamp

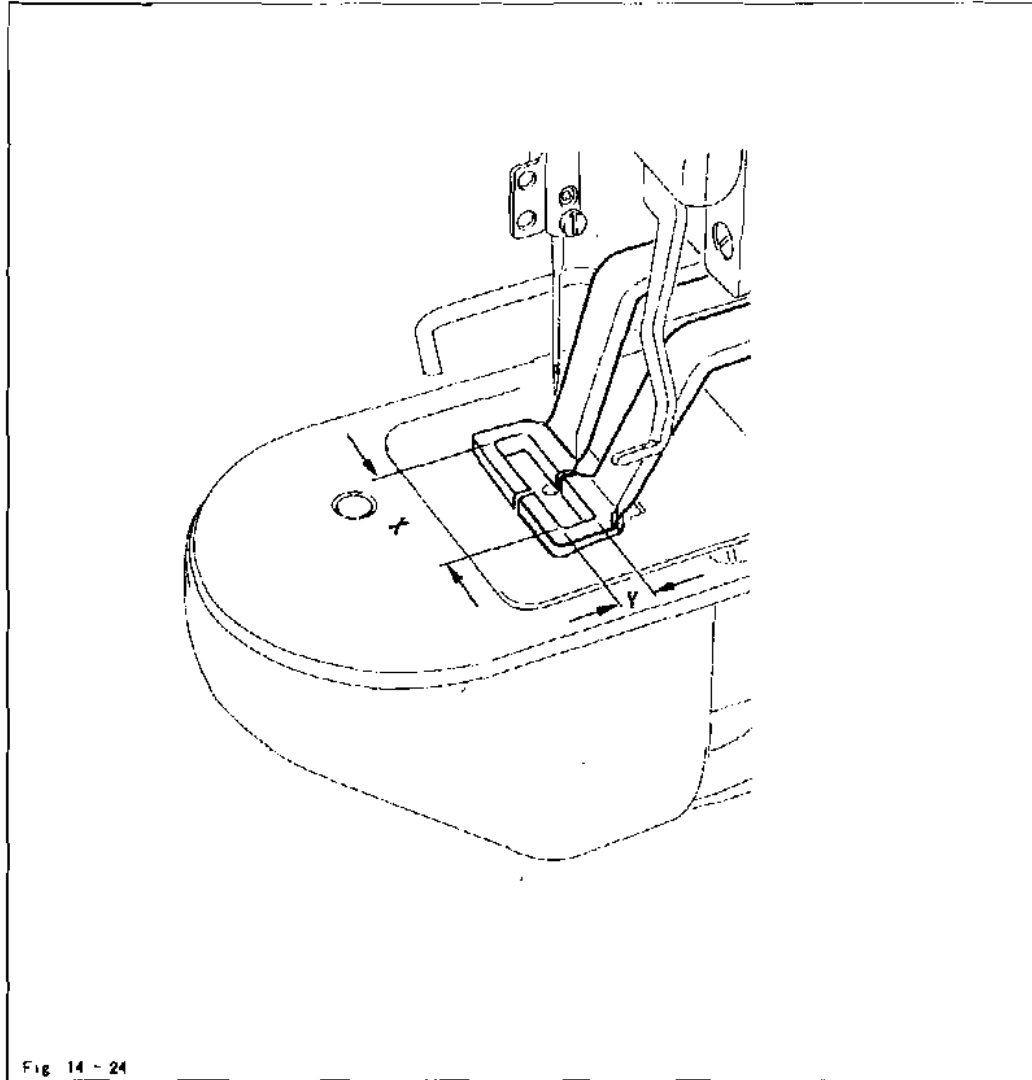

Fig. 14 - 24

- Measure the cutout of the new work clamp in X- and Y-direction.
- Adjust the sewing area size as described in the instruction manual.
- Fit the new work clamp and align it in as described.
- Select the seam program to match the work clamp cutout
- Check the seam program by tacting.



If the actual size of the sewing area differs from the size entered, serious damage can be caused to the machine!

BS 2903

(Different specifications from those of the BT 2900 only are described.)

15 Proper use

The BS 2903 is used for attaching buttons to articles of clothing automatically.



Any and all uses of this machine which have not been approved of by the manufacturer are considered to be inappropriate! The manufacturer cannot be held liable for any damage caused by the inappropriate use of the machine! The appropriate use of the machine includes the observance of all operational, adjustment, maintenance and repair measures required by the manufacturer!

Specifications

16 Specifications

Max. sewing speed: 2500 spm
Sewing speed: 400 – 2500 rpm
Feed type: intermittent
Stitch length: 0.1 – 1.0 mm
Stitch type: 301 (lockstitch)

Fabric clearance: 9mm(standard) max. 13 mm
Max. size of sewing area: 6.5 x 6.5 mm

Noise data:

Noise emission level at workplace

with a sewing cycle of 4 sec. on and 2 sec. off: 83 dB(A)

Sewing head dimensions:

Length: approx. 770 mm

Width: approx. 220 mm

Height: approx. 380 mm

Dimensions of standard base:

Length: approx. 1060 mm

Width: approx. 600 mm

Height: approx. 820 mm

Weights

Sewing head: approx. 42 kilos

Base incl. control box: approx. 45 kilos

* Subject to alterations

17 Control elements

17.01 Balance wheel

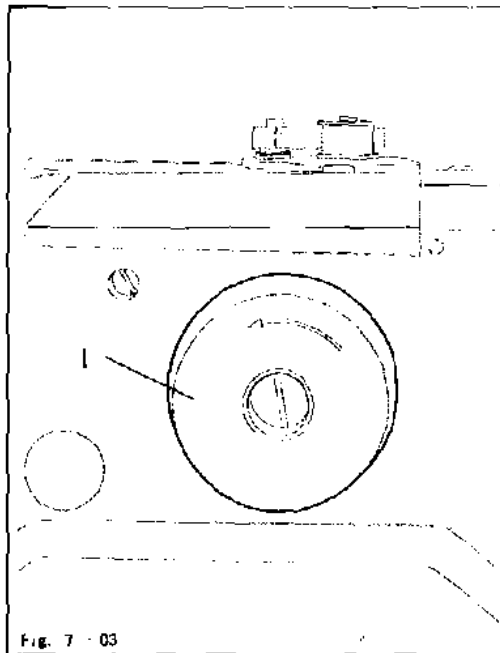

- By pressing and holding down balance wheel 1, it is possible to adjust the needle bar manually.



Release the balance wheel before operating the basic positioner tacting backwards/ forwards keys on the control panel.

17.02 Lever for adjusting the button clamp size

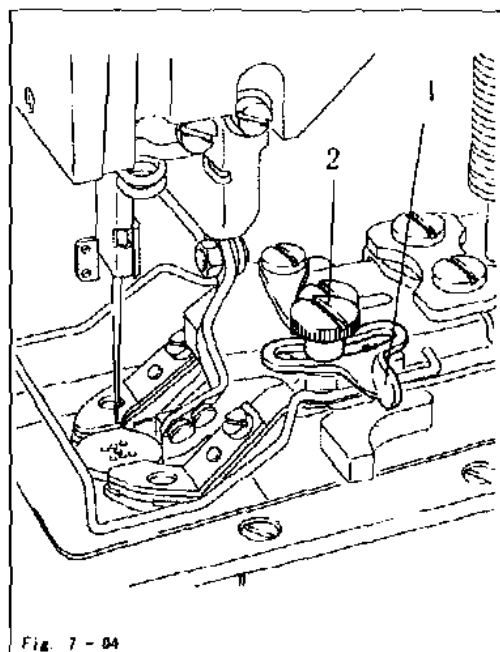

- Adjust lever 1 to set the size of the button clamp. To do so, loosen screw 2



After screw 2 has been loosened, the clamp jaws close automatically! Danger of crushing in the button clamp zone!

Setting up

18 Setting up

18.01 Adjusting the size of the button clamp and sewing area

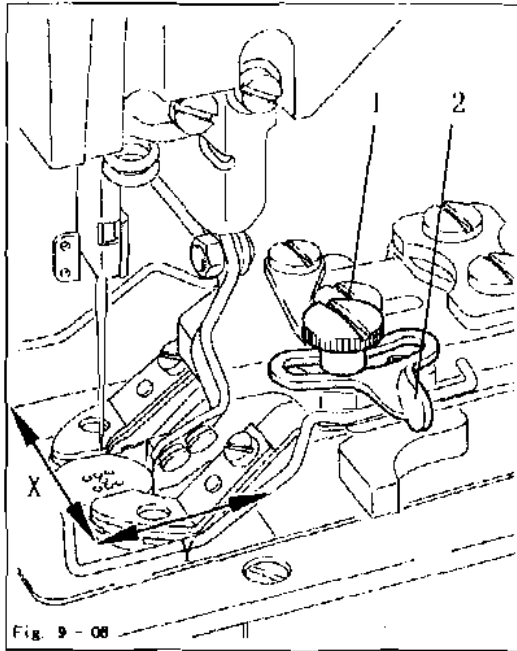

A comparison between the sewing area size entered and the actual sewing area size of the button clamp ensures that seam programs, which extend outside the sewing area size, cannot be sewn.



If the actual and the entered sewing area size do not concur with each other, severe damage can be caused to the machine!











- Loosen screw 1 and with lever 2 adjust the button clamp size to match the button being sewn.
- Measure the sewing area size.













Take care that the feed dog cut-out and the needle plate insert do not collide.











19 Input

19.01 Summary of the seam patterns

No.	Seam pattern	Size of sewing area [mm]	Penetrations/ button row	Total number of stitches
P1		3.4 x 3.4	6	18
P2		3.4 x 3.4	8	22
P3		3.4 x 3.4	10	26
P4		3.4 x 3.4	12	22
P5		3.4 x 3.4	6	22
P6		3.4 x 3.4	8	26
P7		3.4 x 3.4	8	26
P8		3.4 x 3.4	12	3
P9		3.4 x 3.4	6	18
P10		3.4 x 3.4	8	22
P11		3.4 x 3.4	10	26

Input

No.	Seam pattern	Size of sewing area [mm]	Penetrations/ button row	Total number of stitches
P12		3,4 x 3,4	6	18
P13		3,4 x 3,4	8	22
P14		3,4 x 3,4	10	26
P15		3,4 x 3,4	6	22
P16		3,4 x 3,4	8	26
P17		3,4 x 3,4	10	30
P18		3,4 x 0,0	6	11
P19		3,4 x 0,0	8	13
P20		3,4 x 0,0	10	15
P21		3,4 x 0,0	12	17
P22		3,4 x 0,0	16	21

No.	Seam pattern	Size of sewing area [mm]	Penetrations/ button row	Total number of stitches
P23		0.0 x 3.4	6	11
P24		0.0 x 3.4	10	15
P25		0.0 x 3.4	12	17
P26		3.4 x 3.4	6	18
P27		3.4 x 3.4	10	26
P28		3.4 x 3.4	6	22
P29		3.4 x 3.4	10	30
P30		3.0 x 2.6	5	20
P31		3.0 x 2.6	8	29
P32		3.0 x 2.6	5	20
P33		3.0 x 2.6	8	29

Adjustment

20 Adjustment

20.01 Aligning the button clamp

Requirement

The button clamp should be aligned in "X" and "Y" direction, so that the needle penetrates the centre of the gauge button.

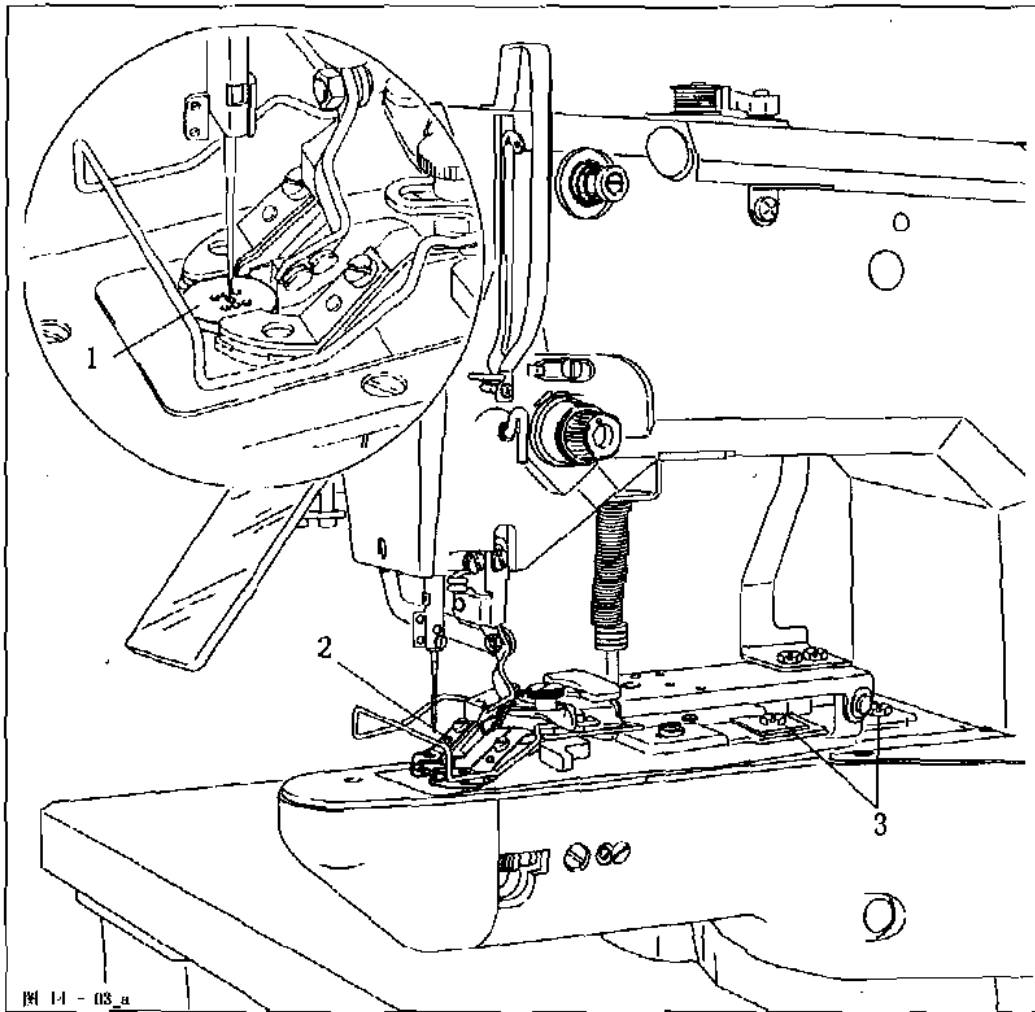

- Insert gauge button 1 and switch on the machine.
- Adjust button clamp 2 (screws 3) in "X" and "Y" direction in accordance with the requirement.



- Conclude the input, remove the gauge button and switch off the machine.

20.02 Button clamp height

Requirement

The button clamp should be 13 mm above the upper edge of the needle plate.

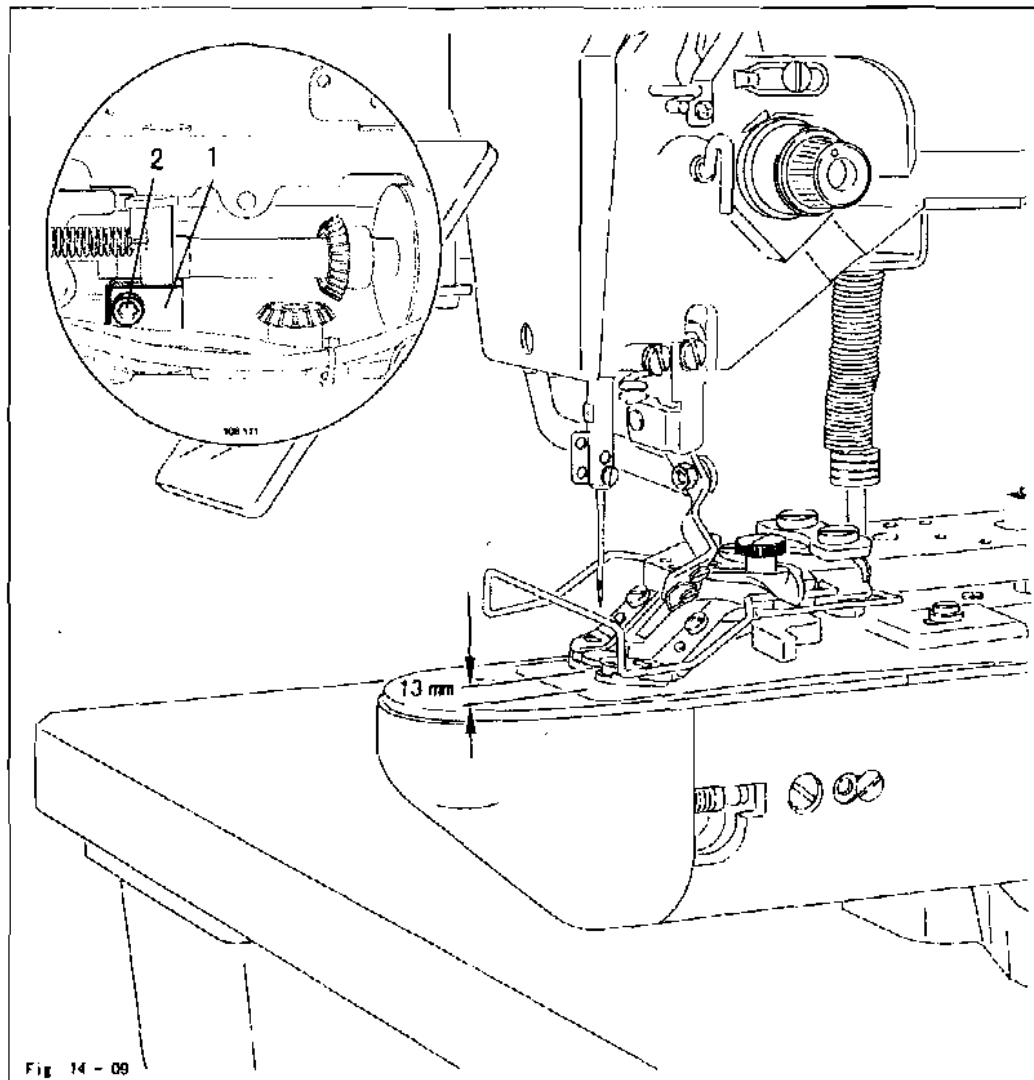

- Turn lever (nut 2 and screw 3) in accordance with requirement .



After aligning the button clamp, it is imperative to check the position of the thread wiper, see Chapter 14.16 Position of the thread wiper! Danger of needle breakage!

Adjustment

20.03 Button clamp pressure

Requirement

The pressure of the button clamp should be set so that the workpiece can be held reliably without pressure marks.

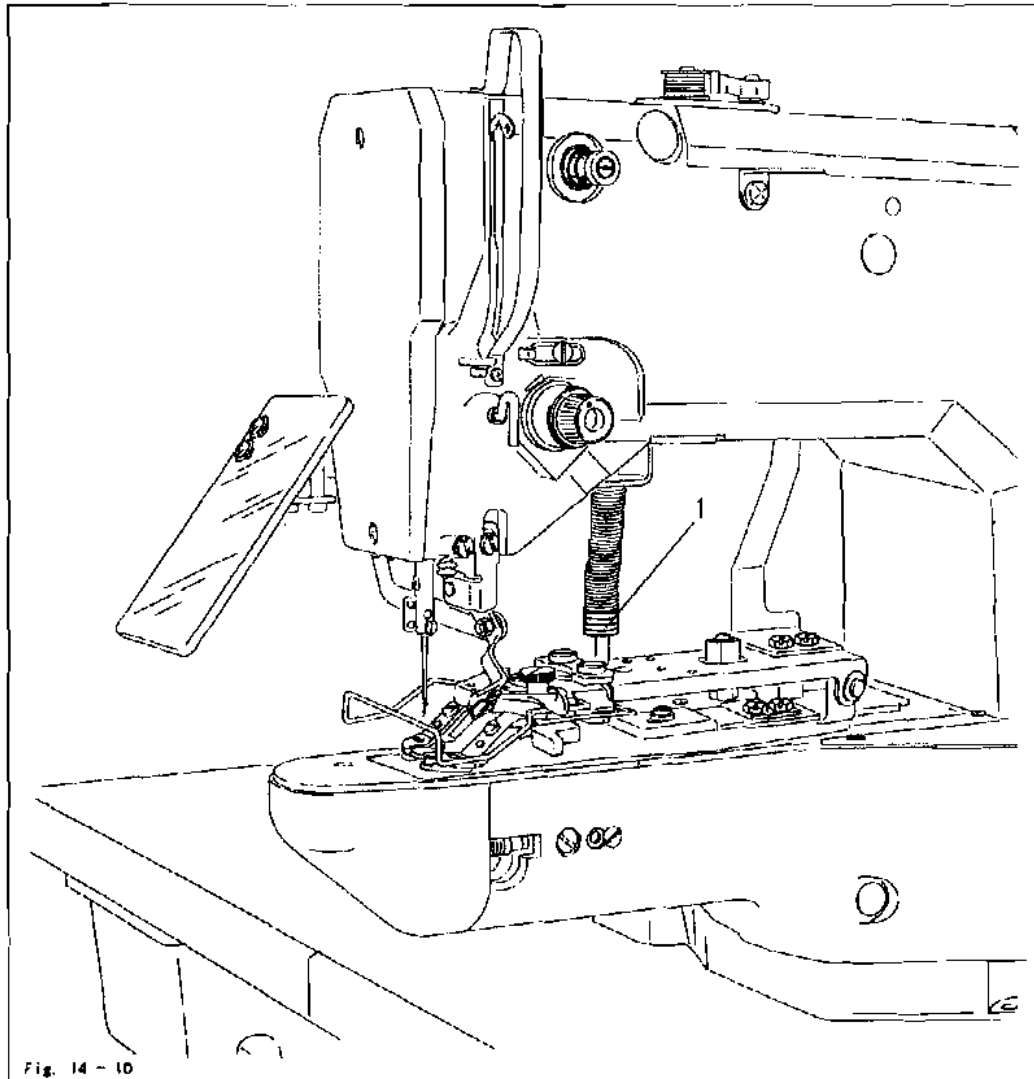

- Adjust milled screw 1 in accordance with the requirement.